

User Manual M-Center

Document Reference: 2151

Version: 1.6

Date: 25.09.2024

Inhaltsverzeichnis

1 General	5
Safety Instructions	5
Maintenance	5
Disclaimer / Liability Exclusion	5
Duties of the Customer	5
Data & Security Backup	5
Monitoring Obligation	5
Access Authorization	6
Responsibility for the IT-Environment	6
2 System	7
Connection Diagram	7
Physical Interface	7
Software Interfaces	8
Buttons on the Device	8
Operational States	8
3 Connectors	9
Power Supply	9
Network Cable	9
M-BUS	9
Cable Length	9
Topology	10
USB-C	10
Modbus	10
Modbus Cable	10
Modbus Topology	10
FLEX I/O	11
Power supply	11
Configure Flex I/O	11
Connection diagram S0 Input	11
FLEX I/O as S0 Input	12
Reset the Virtual Meter	12
4 Startup	13
Network Configuration	13
Access the M-Center through the Web Interface	13
5 Overview Web Interface	14
6 Settings	15
General Settings	15
System Information	16
User Management	17
Change Password	17
Automatic Scan or Manually Add Device	17
Automatic Scan	18
Manually with Add M-Bus Devices	18
Add M-Bus or Modbus Devices Manually	19
Example of integration of an EMU Professional II Modbus RTU meter	20
Event Log	21
Network	22
Enable NAT on Service-Port	22
FTP Server	22
M-Bus Drivers	23
Import	24
Export	24

Create and Edit Drivers	24
Apply Drivers	25
Level Converter	25
Tariffs	25
MQTT	26
MQTT Topics	27
BACnet IP	28
BACNet BBMD	29
Automatic Upload into Joulio-Web	29
Save and Load Configuration	29
Manual Data Export	30
API	30
Reboot	31
Logout	31
7 Device Management	32
Configuration of Device Registers	33
Modbus Server	34
Example	37
8 Troubleshooting	38
One or more Devices cannot be read	38
No Device can be read	38
Multiple Devices cannot be read	38
One Device cannot be read	38
Measurement on the M-Center differs from the Measurement on the Device by a Constant Factor	38
FTP-Upload Fails	38

Version	Revision Date	Token	Changes
V1.1	17.10.2023	met	Initial English version
V1.2	26.02.2024	met	Update new GUI
V1.3	10.04.2024	fbo	Release 240408
V1.4	03.05.2024	met	Added API description
V1.5	12.06.2024	met	MQTT Broker Topics described
V1.6	25.09.2024	met	FLEX I/O Input added

General

Safety Instructions

Please read this user manual as well as all other supplementary documents for the EMU M-Center carefully.



Please pay special attention to the safety instructions and warnings when using the EMU M-Center and this user manual. Nonobservance can lead to substantial damage to persons and/or property.

Please use the EMU M-Center only in its certified area of operation. Nonobservance of these boundaries can lead to substantial damage to persons and/or property.

Unauthorized changes to the EMU M-Center voids all warranties and precludes any and all rights for compensation on the part of EMU Electronic AG in case of damage.

The usual local security and work rules must be observed. The installation of the EMU M-Center must be carried out by qualified and trained personnel. Please read the installation instructions carefully.

The following symbols indicate areas where special attention is necessary:

-  This symbol combined with the word "Note:" is used to describe important information, an important procedure or handling.
-  This symbol indicates a potentially dangerous situation where nonobservance of these warnings can lead to substantial damage to persons and/or property.

Maintenance

The EMU M-Center is maintenance free. In case of damages (for example incorrect operation or incorrect storage) repairs may only be carried out by EMU Electronic AG .

Disclaimer / Liability Exclusion

The choice of the EMU data logger and determination of the suitability of the data logger for a particular purpose are solely the responsibility of the buyer. EMU Electronic AG takes no responsibility for this.

Data / information in catalogs and data sheets do not promise special properties but are determined by experience and measurements.

Liability for damages caused by improper operation / projecting or malfunction of the data logger is excluded. The operator / project engineer must take care that improper operation / planning and malfunctions cannot cause further damage. No warranty is given for defects or damage caused by improper use of the EMU M-Center or by not following the manual.

Duties of the Customer

Data & Security Backup

The customer is responsible for a suitable data backup regardless of the type of installation of the EMU M-Center. The risks and costs of operation lie with the customer. EMU can help with developing possible concepts for operation within the scope of further services.

The responsibility for establishing the required readout and security-backups for safe operations lie with the customer. The security-backups must be stored securely by the customer.

Monitoring Obligation

The customer is obligated to monitor the EMU M-Center to identify outages as soon as possible within the first 24 hours of the outage.

Access Authorization

The customer is responsible for the technical and organizational security against unauthorized third-party involvement for the EMU M-Center.

Responsibility for the IT-Environment

The customer is responsible for their IT-environment as well as the safeguarding of its access.

It is brought to the customers attention that the EMU M-Center as well as it's firmware updates have certain system requirements. It is the responsibility of the customer to conform to these requirements. It is the exclusive responsibility of the customer to provide the necessary hardware and personnel required for the EMU firmware.

The customer is advised to take precautions in case of partial or full failure of the EMU M-Center (e.g. daily backups, interference diagnosis, regular examination of measurements, contingency plans). It is their sole responsibility to provide necessary infrastructure and ensure functionality of the work environment and its technical capability.

The initial system requirements can change during operation or due to an update. The customer is responsible for keeping themselves up to date on these requirements and to ensure system compatibility before installing updates.

System

Connection Diagram

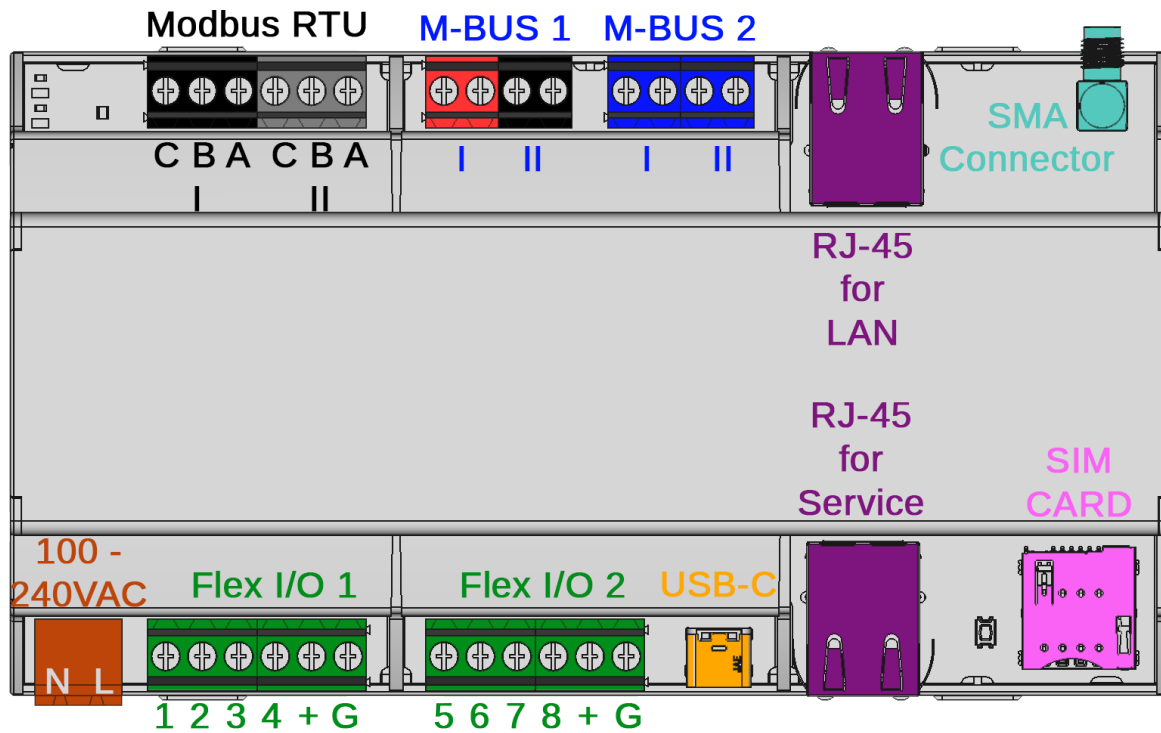

Physical Interface

Power supply

The M-Center needs a 230VAC supply voltage with a minimum current of 1A. (see connection diagram, brown colored)

Network

Two RJ-45 connectors which allows remote access via a web browser. (see connection diagram, violet colored)

2x M-BUS

Two parallel M-Bus connector terminals for practical wiring. The two terminals are internally connected to a single string. (see connection diagram, blue colored)

8x FlexIO

Eight freely programmable Inputs/Outputs with the possibility of two different supply voltages. (see connection diagram, green colored)

USB-C

USB Host connector for specific peripheral devices. (see connection diagram, orange colored)

SIM Card

The EMU M-Center has a slot for a SIM Card. (see connection diagram, red colored)



Attention: Please make sure to disconnect any power from the M-Center before the insertion or extraction of the SIM Card.

Modbus RTU (RS-485)

Two RS-485 connectors for two Modbus strings with Modbus readout. (see connection diagram, black colored)

SMA Connector

The EMU M-Center has a SMA connector for an LTE antenna. (see connection diagram, petrol colored)



Attention: Please make sure to disconnect any power from the M-Center before attaching the antenna.

Software Interfaces

Web browser

The M-Center has an integrated web server for easy configuration of the M-Center. You can also check the data from connected devices on this web browser.

FTP-Export

Export a file for each readout interval and device. Select freely between the .csv and .json format. The M-Center supports the FTP, FTPS and SFTP protocols.

Cloud-Upload

Interface to the “Joulio-Web” energy management system.

BACNet & BACNet BBMD

Allows the integration of measurements into the automated systems of a building via BACnet.

Level Converter

Allows the use of the M-Center as a level converter. If active you can manually read out connected M-Bus devices via USB or TCP.

Buttons on the Device

The M-Center has a “Reset” button and a “Recovery” button which are found next to the SIM Card.

The “Reset” button is akin to disconnecting the power supply of the M-Center. This can lead to corrupted internal memory and should be avoided unless absolutely necessary. For a secure reboot of the M-Center please use the **Reboot** option on the web page. This reboot requires a confirmation.

The “Recovery” button is needed in special cases for an Update of the M-Center. Only use this button if you have been explicitly instructed to do so by the EMU Electronic AG support.

Operational States

The EMU M-Center has a status-LED next to the Modbus connectors. The following table describes the color and blink patterns.

Color and Blink Patterns	Description
Blinks red in a 0.5s cycle	Short circuit or overload on the M-Bus
Blinks between blue and green in a 0.1s cycle	The M-Bus level converter is active
Blinks blue in a 0.7s cycle	The M-Center is scanning for devices
Blinks blue in a 0.1s cycle	The M-Center is currently reading out device data via M-Bus
Permanently green	The M-Center is in stand-by mode

Connectors

This chapter describes the M-Center connectors in detail.

Power Supply

The M-Center needs a 230VAC (100 - 240VAC) supply voltage with a current of at least 1A. The connectors are on the lower left.

Network Cable

The EMU M-Center has two RJ-45 LAN connections. The connections are on both sides of the device. The connection on top is meant for LAN, the lower connection for the service of the M-Centers.

- The LAN Port is set to DHCP ex-factory.
- The Service Port has a fixed IP: 169.254.254.1. Computers connected to the service port are given an IP-address automatically via DHCP and need not have their network settings configured for connecting to the M-Center.



Note: The service port is meant for a direct connection with a computer.

M-BUS

The EMU M-Center has two parallel M-Bus connectors. They are found on the upper terminal. For further information regarding the M-Bus setup with a EMU Professional II M-Bus please consult the documentation "Manual M-Bus EMU Professional II" Doc.Ref: 1480.

Cable Length

The maximal Bus length is dependent on the following factors:

- Number of slave devices on the bus. The more devices the shorter the possible bus length.
- Readout baud rate. A lower baud rate (300) allows readout over longer distances, while higher baud rates (9600) have the opposite effect.
- Bus cross-section. A greater diameter ($>0.8mm^2$) allows for greater distance readout.

With the following assumptions, a maximum bus length of 1 - 1.5km is viable

Description	Value
Baud rate	2400
Cable in use	$2 \times 0.8mm^2$
Capacity of one M-BUS device	$1nF$
Avg. current of one M-BUS device	$1.5mA$



Note: These specifications are only to be used as a reference. The possible segment length may vary. Generally it is recommended to keep the segment length to a minimum.



Note: The maximum amount of devices connected on the M-Bus depends on their current draw. An EMU Professional II has a standard draw of $1.5mA$ (1 unit load) while certain water and heat meters draw up to 4 unit loads. The maximum M-Bus load on the M-Center is $375mA$ (1 unit load = $1.5mA$).

Topology

You are free to choose between star, bus or tree topology. Depending on your needs, a mix of the three is also possible.

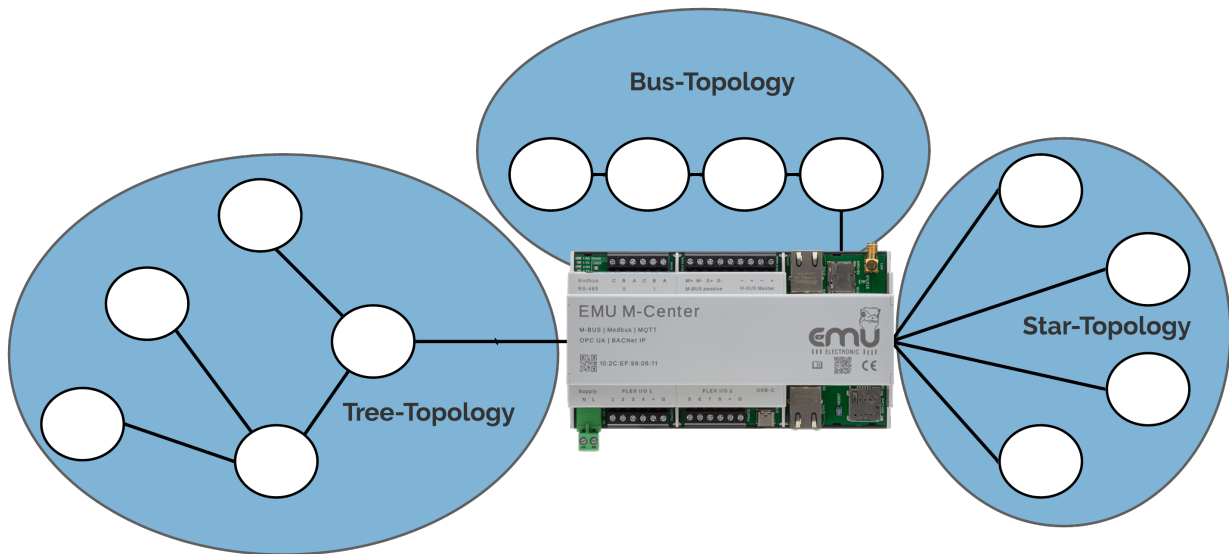

Note: M-Bus does not allow for a ring topology.

USB-C

The USB-C port is used for the level converter. Connect your computer with the USB port and access the M-Bus via the virtual COM port.



Danger: Connecting a power supply to the USB-C port can lead to the destruction of the M-Center.

Modbus

The EMU M-Center has two sets of Modbus connectors. These can be found on the upper terminal. You can connect up to 32 Modbus devices per string. For further information regarding the Modbus setup with a EMU Professional II Modbus please consult the documentation "Manual Modbus EMU Professional II" Doc.Ref: 1485.

Modbus Cable

For interference-free communication via Modbus, it is best to use a shielded, twisted pair cable (telephone cable). Please note that the shield must be connected to pin C (GND).

The absolute maximum cable length between the M-Center and the connected Modbus device is 1200m, whereby "shorter is better" applies. The main line of the bus should not be longer than 700m.

Modbus Topology

For Modbus please use the bus-topology. The main string needs a 120Ω terminating resistor.

FLEX I/O

The EMU M-Center has 8 flexible inputs/outputs. The 8 connections are divided into 2 terminal strips. Each terminal strip is powered separately.

The 8 FLEX I/Os can only be switched in groups of two between input and output. These groups are

- FLEX I/O 1 + 2
- FLEX I/O 3 + 4
- FLEX I/O 5 + 6
- FLEX I/O 7 + 8

As an example, connections 3, 4, 5, 6, 7 and 8 can be configured as outputs, while connections 1 and 2 are configured as inputs. However, if you require an additional input later, one of the other groups must be configured as input.

Power supply

Both terminal strips can be supplied with an external voltage of up to 36VDC via the “+” and “G” connections. Terminals 1-4 do not have to have the same supply voltage as terminals 5-8.

Configure Flex I/O

To configure a FLEX I/O group go to “Settings” → “Flex I/O” on the M-Center website. In this view, you can customize the connection groups according to your requirements.

- Not active: This connection group is not activated. Any signals at these terminals are ignored.
- Input (S0 pulse detection): This connection group is configured as a pulse counter. Every time a “high” is present at one of these connections, it is recorded and totaled on a virtual counter.
- Output (switching): This feature is in development.

Connection diagram S0 Input

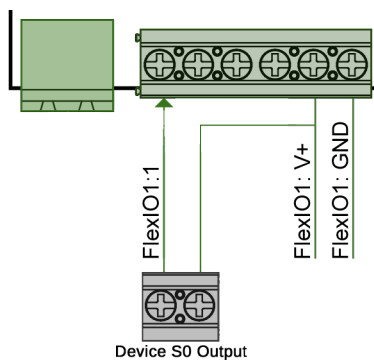

Terminals 1-8 are high-active, so the S0 wires are connected to V+ and the Flex I/O input. Each time the S0 output of the measuring device outputs a pulse, the V+ voltage is switched to the terminal on the M-Center.

FLEX I/O as S0 Input

Once you switch a connection group of the FLEX I/O to input, the associated virtual meters are created in the “Other” counter category. By default, these are named after the FLEX I/O terminal (e.g. “FLEX I/O 1”).

Virtual Meter

The following settings can be changed by clicking on the virtual meter:

- Name: Change the display name of the virtual counter
- Location, cost center, comment: These fields are optional and are used to differentiate between meters.
- Medium: Select in which of the meter categories this pulse input should be displayed.
- Serial number: The serial number of the virtual meter can be important for downstream systems.
- Manufacturer: This field is optional and is filled in with ‘S0’ by default.
- Readout cycle: This setting specifies the cycle in which virtual load profile entries are saved for this virtual meter. This setting has no influence on the update frequency of the pulse values on the M-Center website.
- BACnet IP: Specify the instance number of the virtual meter for your BACnet.

You can further edit the virtual counter by clicking on the arrow to the right of the “Edit” field.



Note: While in this edit mode, all incoming pulses on this input are ignored.

The screenshot shows the M-Center interface. At the top, it displays 'Flex I/O 4' and 'Last reading: 09/10/2024 04:02:45 PM · Manufacturer: S0 · Medium: Other · Modbus TCP Server device number 15'. Below this is a search bar and a table with one entry: '0 None S0-4' with 'Logging: On' and 'register: 0'. An 'Edit' button is visible next to the entry. On the right, the 'Edit Device Data' dialog is open, showing fields for:

- Generic Name: -- not yet configured --
- Name (Other): S0-4
- Tariff: -
- Phase: -
- Unit: -- not yet configured --
- Unit (Other):

General

- Name: Select the name and designation of the imported value.
- Tariff and Phase: These fields are optional and are used to specify the value read out via S0.
- Unit: Enter the unit of the S0 value read out.
- OBIS code: Enter the OBIS code of the S0 value.

The “Save to database” option must be activated if you want to save the read values to the M-center.

Flex I/O input

- Meter reading: Enter the current value at the time of connection to the M-Center. This value serves as the starting point for further accumulation on the M-Center. If no value is specified, the virtual counter starts at 0. This can lead to discrepancies between the virtual meter readings on the M-Center and the real values on the meter.
- Pulse ratio: If the real meter outputs the pulses with a ratio (e.g. 100 pulses/kWh), this must be entered here. Otherwise, the values on the virtual meter will differ from the real values on the meter.

Reset the Virtual Meter

To reset a FLEX I/O input and the associated virtual meter (e.g. if a meter is replaced), first delete the virtual meter and then restart the M-Center. After the restart, a new virtual meter is created automatically.

Startup

This chapter describes the recommended steps in configuring a newly installed M-Center. It is always possible to configure the device further later.

After successfully connecting the M-Center, the device may be configured.

Network Configuration

The EMU M-Center is set to DHCP ex-factory.

To setup the EMU M-Center on location, a laptop can be connected via the service LAN interface. The connection has the fixed IP-Address 169.254.254.1. Computers connected to the service port automatically receive an IP-address via DHCP. The EMU M-Center can be configured via the web interface reachable with this address.

Service Port = Fixed IP-Address 169.254.254.1

For a remote setup, the EMU M-Center must be in the same network as your computer. You can now get the IPv4-Address of your M-Center by opening the command line interface and entering the following:

```
ping mcenter-'mac-address'.local -4
```

The serial number of your M-Center is also its MAC-address and is printed onto the M-Center casing. Example with a M-Center with the serial number and MAC-address 10:2C:EF:12:34:56

```
ping mcenter-102cef123456.local -4
```

Access the M-Center through the Web Interface

If the M-Center has a valid IP configuration, the device can be reached via their IP-address in any web browser.

The default access data ex-factory for the M-Center are as follows:

- User name: admin
- Password: 123



Login

Username

Password

Remember me

[Forgot password?](#)

Sign in



Note: It is recommended to change the default password as soon as possible.

Overview Web Interface

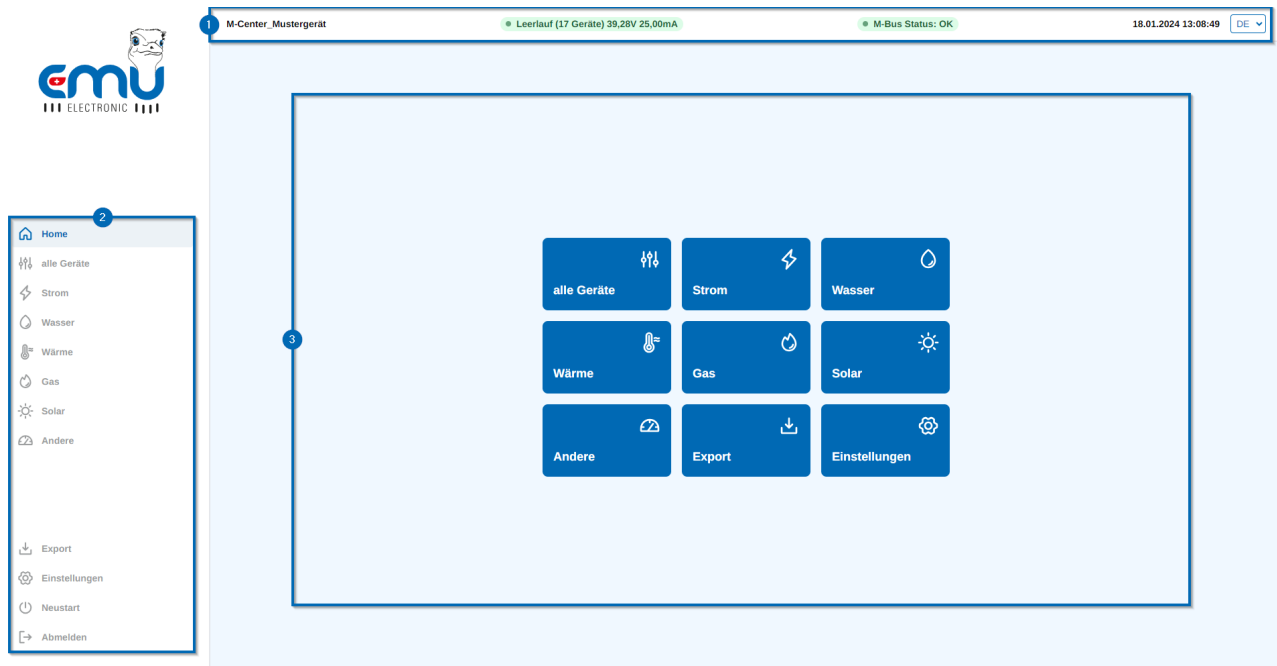

1. The status bar shows the following information from left to right.

- Name of the M-Center. The name can be changed in the settings.
- Current activity of the M-Center (Idle, reading, scanning, etc.)
- Number of configured devices in brackets
- Bus voltage
- Bus current
- M-Bus status
- Current time and date
- Language settings. You can set the M-Center language here.

2. The left sidebar is for navigation. This sidebar is always visible.

- The upper section is listing all connected devices. You can list them all with “All Devices” at once or in their respective category (“Electricity, Water, ..”). The device category can be set in the device settings.
- The lower section includes manual device data export, M-Center settings, remote reboot of the M-Center and the logout button.

3. The main screen.



Note: Expanding the scope of operation of the M-Center with additional licenses is possible at any point. Please contact your distribution partner for more information.

Settings

Click on “Settings” in the left sidebar.

- “General Settings”
- “User Management”
- “Scan”
- “Add M-Bus Device”
- “Event Log”
- “Network”
- “FTP”
- “M-Bus Drivers”
- “M-Bus Level Converter”
- “Tariffs”
- “MQTT”
- “BACnet IP”
- “BACnet BBMD”
- “Joulio-Web”

General Settings

The tab “General Settings” allows you to customize and setup your M-Center.

- Recommended settings:
 - To ensure correct time stamps on your readouts you must set a **NTP-Server** (E.g. ch.pool.ntp.org). If any NTP server is reachable the M-Center synchronizes automatically with it. This setting is essential for correct timestamps on the measurement values.
 - The **M-Bus readout timeout [ms]** sets the time before the M-Center interprets a missing answer from M-Bus devices as a timeout. The default timeout is 3s (3000ms). A Zero in this field sets the timeout to the default value (3s).
 - **Standard readout interval** sets the interval in which the M-Center reads all connected M-Bus devices.
 - By default, the M-Center ignores date and time information in the M-Bus telegrams. Activate the option **interpret time and date values during M-Bus readout** to ensure that the date and time information is read and interpreted.
 -  **Note: This option *must be set before* adding any devices. Activating this option can lead to faulty readouts on devices added before activation.**
- Optional settings:
 - **Name** optionally lets you set the name of the M-Center in the status bar. This name is only visible on the web interface.

- **Location** lets you describe the place of installation.
- **Save** your settings by clicking on the blue “Save” button or discard any changes by leaving the sub menu without saving.

The following options must be activated and then confirmed before they come into effect. Each option has its own confirmation button which only appears once the option has been selected.

- With the option **Immediate Read-out** you can start a readout of all connected devices. Be aware that depending on the number of connected devices this readout may take some time.
- The option **Set date and time manually** lets you set the system time on the M-Center. This setting is only recommended on installations where access to any NTP-Server is not possible.
- The option **Delete all devices and measurements** deletes all connected devices and their data from the M-Center.

Further Information Readout Interval

The following readout intervals for M-Bus are available:

15min (default), 20min, 30min, 45min, 60min, 90min, 120min, 150min, 3h, 6h, 12h, 18h, 24h, 48h, 168h (7 days), 672h (28 days)



Note: Recommended readout interval on devices without battery: 15 minutes. For devices with a battery, please contact the manufacturer for a recommended readout interval

The minimal readout interval is determined by the readout duration of the connected devices. If a readout cycle for all connected devices goes on for more than 15 minutes, a slower interval must be chosen. Alternatively, each device can have an individually set readout interval.

The M-Center supports raster readout:

- On a chosen interval of 15 minutes the readout starts at .00, .15, .30, .45 respectively.
- On a chosen interval of 1 hour the readout always starts at the full hour.



Note: By default the M-Bus readout cycle is 15 min.

System Information

This sub menu displays a detailed status of your M-Center. It also lists the name, serial number (MAC-address) and firmware version.



Note: The firmware version is displayed twice. Once in black on white and once in red. The red version shows the latest firmware release while the black one shows the currently installed firmware.

This menu also displays all interfaces. Modbus TCP and Modbus RTU interfaces list the number of connected devices if a valid license is activated. The M-Bus interface furthermore lists the bus-current and bus-voltage.

At the bottom you can find the status of these interfaces, as well as the available memory capacity in percent.

User Management

Here you can create new users and modify existing ones.

The screenshot shows the 'User Management' interface. On the left is a 'Settings' sidebar with options like General Settings, User Management (selected), Scan, Add M-Bus Devices, Eventlog, Network, FTP, and M-Bus Drivers. The main area is titled 'User Management' and contains a form with the following fields: Username, Firstname, Lastname, Locale string (dropdown menu), Group list (dropdown menu), and Comment. Below the form is a large blue 'Add' button. Underneath is a list of existing users:

admin · nr operator	Locale string: English · groups: admin,operator · Comment: -	Edit	Delete
testUser1 · Peter Meier	Locale string: English · groups: operator · Comment: Tester	Edit	Delete

This list shows all existing users. The user “admin” is the default user and exists ex-factory. You can edit and delete users in this list.

- Add a **User name**. This name is required for the login.
- You can add the user to a **Group List**.
- Choose which **Locale string** you prefer for the user.
 - Englisch
 - Deutsch-Schweiz
 - Deutsch-Deutschland
 - Deutsch-Österreich
 - Espanol
 - and more
- With the optional fields **First name**, **Last name** and **Comment** you can personalize the user further.

Save the new user, or changes to existing users by clicking on the **Add** button. Cancel or discard any changes to a user by leaving the sub menu without saving.



Note: The difference between the three German languages is amongst other things the thousands separator in exported files (.csv, .json).

To set the password for a newly created user you need to log out with the current user and log in again as the new user. The new user does not have a password so leave the password field empty. Once you logged in you can change the password in these settings. In case of a new user the field “current password” can be left empty.

Change Password

To change the password of a user you need to be logged in as this user. Go to the “User Management” setting and click on “Edit” on this user. Three new fields should appear:

- current password: enter the old password. If you are setting the password for the first time for a new user, you can leave this field empty.
- Enter new password: Enter your desired new password.
- Repeat new password.

Automatic Scan or Manually Add Device

You can scan for connected devices manually or let the M-Center search for them automatically. Once connected devices have been added to the M-Center, you can configure them on the web interface.

Automatic Scan

Any devices connected to the M-Center via M-Bus can be scanned for automatically or through its primary or secondary address. The automatic scan can be done over all or just one baud rate.

Follow these steps to add devices to the M-Center:

- Click on **Scan** in the configuration menu
- Choose the preferred baud rate (recommended baud rate: 2400). Choosing specific baud rates may shorten scan time.
- Choose between a data logger readout or the normal momentary values readout. This option only works with EMU Professional II energy meters and must be set ahead of scanning.
- Choose address type
 - A secondary address scan scans for all addresses
 - On a primary address scan, you can restrict the scanned address range
- Start the scan with the “scan” button



Note: The data logger readout only works on the EMU Professional II energy meter. Any devices from other manufacturers added with this option activated are added as if the option were not active.



Note: Be aware that connected Professional II energy meters synchronize their time over M-Bus. For a correct data logger time stamp please make sure to connect the M-Center to a network with access to a NTP server. It is strongly recommended to connect the M-Center to a NTP-Server.



Note: A Professional II energy meter that is added with the data logger readout will have its entire data logger read out. This can lead to long readout times. The M-Center can read out 8 days' worth of data logger entries (default data logger interval of 15min) in one hour.

Manually with Add M-Bus Devices

To add a device manually please go to **Add M-Bus Devices** and enter the baud rate, the address type and the address of the device in the corresponding fields. Click on “Add” to save this device into the list.



Note: The medium of M-Bus devices is encoded in the M-Bus telegram. If your device does not show up in the expected category you can change the medium later manually.

Add M-Bus or Modbus Devices Manually

You can add your devices directly in the respective device categories. For this, click on the symbol as shown in the picture below. You can find this symbol in each of the different device lists.

The screenshot shows the M-Center interface. On the left is a sidebar with 'Home', 'All devices', and 'Electricity'. The main area displays 'all devices' with a 'number of devices: 18' and a 'Sort by' dropdown menu highlighted with a red box. Below this is a search bar and a list of devices, each with an 'Edit' button and a right-pointing arrow. The devices listed are:

- HVT Cold 0 143540 - 02/02/2024 01:45:01 PM
Primary address: 0 - Secondary address: 143540 - HVT
- AMT Wate 0 51884601 - 02/02/2024 01:45:02 PM
Primary address: 0 - Secondary address: 51884601 - AMT
- SON Heat 0 15227671 - 02/02/2024 01:45:04 PM
Primary address: 0 - Secondary address: 15227671 - SON

In this window you can choose which kind of device you want to add. For Modbus RTU devices please make sure you choose the correct strand. Depending on the chosen type, different fields appear.

M-Bus

- Name: Give your M-Bus device a name. You can find this device later under this name.
- Baud rate: Choose with which baud rate you want this device read out.
- Address mode: Choose between primary and secondary address
- Address: Enter the primary or secondary address of your device. This field is dependent on your choice of Address mode.

Modbus TCP

- Name: Give your Modbus TCP device a name. You can find this device later under this name.
- Add the serial number, the IP-address and the port for the device.
- Medium: With this option you can choose in which list the device appears.
- Byte and Word order: These options let you configure the TCP communication.
- To read out Modbus TCP devices please make sure to correctly set up the network configuration on the devices and the M-Center. If you have questions regarding the network configuration, please contact your system administrator.

Modbus RTU

- Name: Give your Modbus RTU device a name. You can find this device later under this name.
- Add the serial number and the Modbus slave address for the device.
- Medium: With this option you can choose in which list the device appears.
- Baud rate, Number of data bits, Parity and Stop-Bit: These options must be adjusted to your Modbus RTU device.
- Byte and Word order: These options let you configure the Modbus communication.

Example of integration of an EMU Professional II Modbus RTU meter

The following example shows how to integrate an EMU Professional II with the Modbus RTU interface.

The meter has the Modbus slave address 1 (device address) and is connected to Modbus RTU line I. All other communication parameters can be found in the Modbus documentation of the EMU Professional II.

Add Device

Interface	Name
Modbus RTU Line I	EMU Prof II 24123456
Serial number	Medium
24123456	Electricity
Device address	
1	
Baudrate	Bytes
19200 Baud	8
Parity	Stop-Bit
Even	1
Byte order	Word order
high (Big Endian)	MSB -> LSB
Cancel	Add

After adding the meter, you can define which registers are to be read out from the EMU Professional II. All available registers are listed in the documentation "Manual Modbus EMU Professional II" Doc.Ref: 1485.

To read out the "Active Energy Import" for tariff 1 in Wh, proceed as follows:

1. Identify the correct register number by adding the name, unit and the desired data type:
 - Register: 6004
 - Data type: uInt64
 - Unit: Wh
2. Add register:
 - Start-Address: 6004
 - Function code: 0x03
 - Type: uInt64

- Name: Active Energy Import
- Tariff: Tariff 1
- Phase: -
- Unit: Wh
- Divisor: empty
- OBIS-Code: 1-0:1.8.1

Add register

Start address	Function code
<input type="text" value="6004"/>	<input type="text" value="0x03 (read holding registers)"/>
Typ	Name
<input type="text" value="uInt64"/>	<input type="text" value="Active energy import"/>
Tariff	Phase
<input type="text" value="Tariff 1"/>	<input type="text" value="-"/>
Unit	Divisor
<input type="text" value="Wh"/>	<input type="text"/>
OBIS code	
<input type="text" value="1-0:1.8.1"/>	
<input type="button" value="Cancel"/>	<input type="button" value="Add register"/>

3. After creating the registers, it is advisable to validate the values. Ensure that the meter readings etc. are interpreted correctly.
4. If the read-out values are to be stored, the "Save to database" option can be activated.

Event Log

This sub menu lists all messages from the M-Center. The following messages are listed here:

- The M-Center sent the time synchronization signal to its connected devices over M-Bus
- A device sends errors
- Cloud upload started/ended
- Start/restart of the M-Center
- FTP upload status
- and more

These messages can be refreshed and deleted with the two buttons on the top right.

Network

In this menu you can configure the LAN interface. By default, the M-Center is set to DHCP.

If DHCP is set, you will only see the MAC-address of the M-Center. The MAC-address is the same as printed on the M-Center casing and functions as its serial number.

To set up the interface manually choose “manual” in the “manual configuration” drop-down menu. Afterwards you can set the fields IP-Address, subnet mask, gateway and DNS-server and save them with the “Save” button.

Enable NAT on Service-Port

This option allows you to connect additional network devices on the service port of the M-Center. The connected devices automatically receive an IP-address from the defined address range in the fields “Service-Port IP address” and “Service-Port Subnet mask” below. Please note that individual IP address ranges are defined when several M-Center devices are cascaded. Devices connected to the service port communicate externally via the IP address of the topmost EMU M-Center.

FTP Server

To configure the automatic data transfer to an external server please click on **FTP** in the settings. Once the “Active” option is set, the FTP settings appear.

If the FTP upload is activated, the M-Center uploads one data file per device per readout interval to your set server. The files are named as follows: < Device ID >-< Secondary address >-< yyyyMMddhhmmss >-< Format >

- Server: Set the IP-address of your server.
- User: Enter the username for the upload.
- Path: Set the path for the uploaded files.
- Port: Set the port to which the M-Center sends the files.
- Password: Enter the password for the upload. You can show the password by clicking on the button on the right side of the password field.

- SSL: Set this option if you want to upload your data with the FTPS protocol

The options “Export type”, “Separator” and “Export Language” lets you customize the uploaded files further.

SFTP

If you want to use the SFTP protocol you need to add it to the server address in the “Server” Field: sftp://[HOST]



Note: The option “SSL” must not be active for the SFTP protocol.

Save the settings by clicking on the blue “Save” button. Cancel or discard any changes by leaving the sub menu without saving.



Note: It may be necessary to change the port if you use SSL. For further questions regarding SSL export please refer to your server provider.

M-Bus Drivers

You can create drivers to simplify the register configuration of connected devices. Once created, these drivers can be used indefinitely. There can be only one driver per device type. A device type is characterized by the following fields:

- Manufacturer
- Medium
- Version
- Number of registers

These fields can be reviewed via the “Edit” button (See 1 in picture below) in the device lists. Choose the M-Bus tab (See 2 in picture below) in the edit menu.

The M-Center comes with drivers for the standard registers for the energy meters EMU Allrounder, EMU Professional and EMU Professional II.

Import

You can import previously created drivers. Choose the .json file of the driver by clicking on the “Import file” field and import it with “Import”. The driver should then appear in the drivers list.

Export

If you have edited or created a driver you can export it for backup purposes or to use it on a different M-Center with the same devices. For this you need to give your export file a name and click on “export”. This exports all drivers on this M-Center as one .json file.

Create and Edit Drivers

Drivers can be created directly in the device settings.

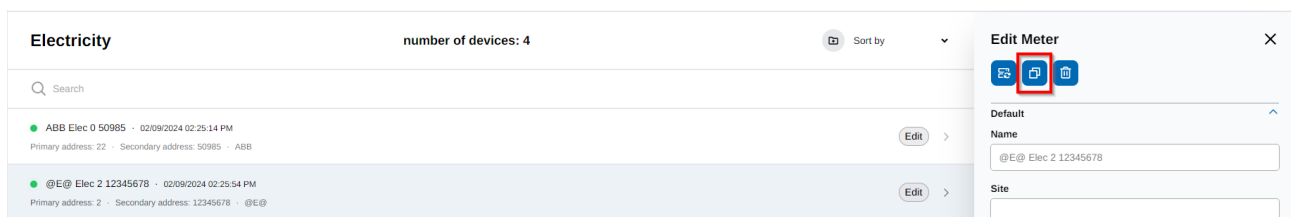

To change the name or readout cycle of the driver please click on “Edit” on the desired driver. In this sub menu you can also set if the devices with this driver applied to are battery operated.

To edit the registers of a driver you need to click on “Expand” (See 1 in picture below) and then on “Edit” (See 2 in picture below) on the desired register.

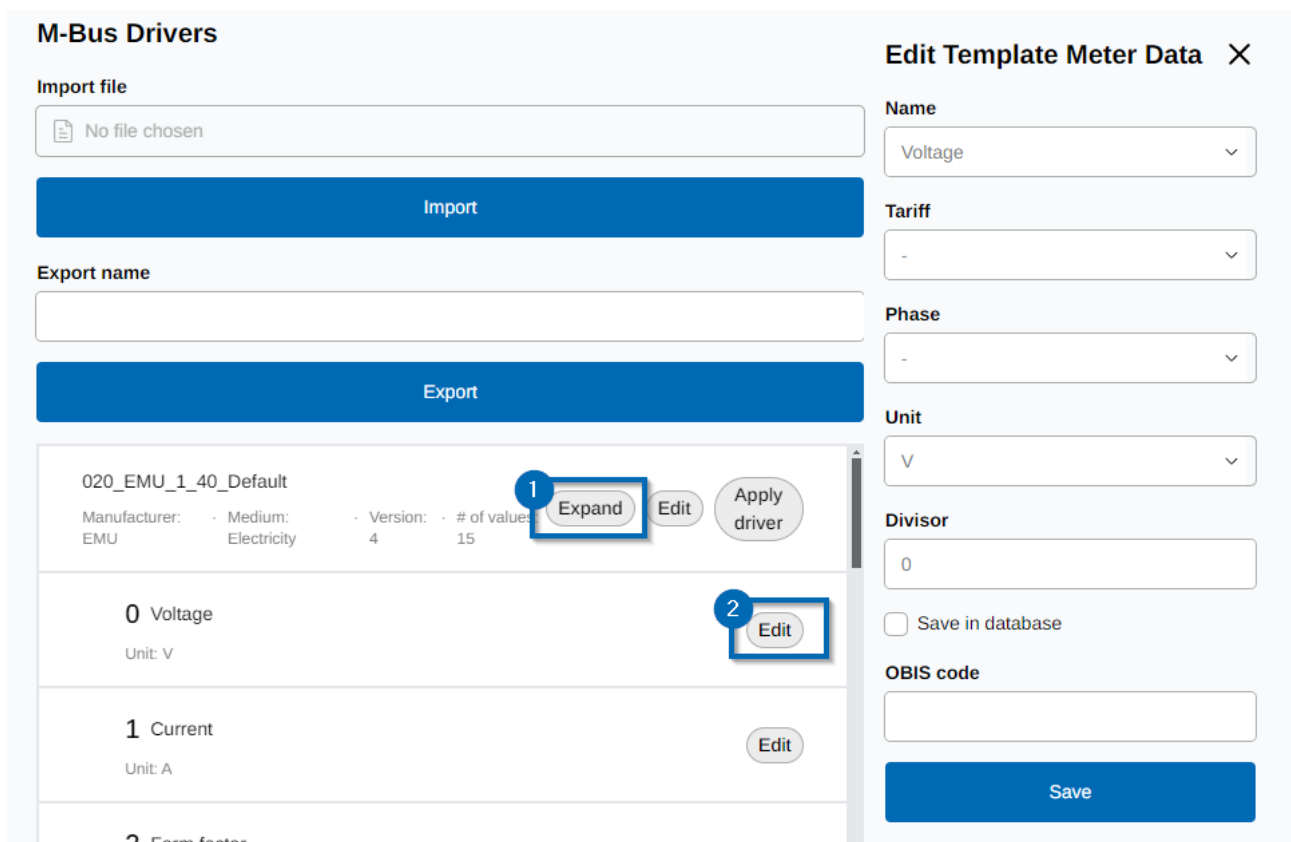

1. Choose the appropriate description in the drop-down menu under “Name”.
2. If the chosen register is of a specific tariff, you can set the tariff here.
3. If the chosen register is of a specific phase, you can set the phase here.
4. Set the unit of the register.

5. Set a multiplicative factor for the read-out values of this register. This factor is automatically applied and can be used for example to convert Wh values to kWh values.
6. Set if the register is logged in the data logger.
7. Add the correct OBIS code to the register.

Apply Drivers

The button “Apply Driver” applies this driver to all devices with identical “Manufacturer”, “Medium”, “Version” and “Number of Values” fields.

Level Converter

The level converter allows for a readout of all connected M-Bus devices over TCP or USB via an external program. It is generally used for diagnostic purposes on the M-Bus as well as a configuration tool for the EMU Allrounder/ Professional registers or other M-Bus devices.

Please enter the correct **Baud rate** if you use the USB port for the level converter and the correct **Port** if you use the LAN port.

Save the settings by clicking on the blue “Save” button. Cancel any changes made by leaving the sub menu without saving.



Note: The level converter must be turned off for the automatic readout of the connected devices. Make sure to deactivate the level converter after use.

Tariffs

The M-Center can send periodic tariff changes to any connected M-Bus meters. For this, the meters must be capable of switching tariffs via M-Bus.

The tariff switch functions as follows. You set a specific time (hour and minute) at which the M-Center sends out the tariff change message in the field “Time of tariff change”. The switch command is then sent out at the set time on all days you choose between and including the “Weekday start” day and “Weekday end” day. You can describe the tariff-switch-command in the field “Name”.



Note: There is no limit to the amount of commands you can add but be aware that the M-Center does not check for overlapping time windows. It is the responsibility of the user to ensure correct tariff commands.

Save the command by clicking on “Add”. The newly created tariff change then appears in the list of commands.



Note: Meters with the load profile certification PTB-A 50.7 will change their tariff only once every 15 minutes. Make sure to choose the switch-time accordingly.

Example day and night tariff on workdays

Name: Tariff during the day

Tariff: 1

Weekday start: Monday

Weekday end: Friday

Time of tariff change: 07:00 AM

Name: Tariff during the night

Tariff: 2

Weekday start: Monday

Weekday end: Friday

Time of tariff change: 08:00 PM

These two tariff commands ensure, that from Monday to Friday the M-Center switches each morning at 7AM from tariff 2 to tariff 1 and each evening at 8PM back from tariff 1 to tariff 2.

MQTT

The screenshot shows the 'Settings' page with a sidebar on the left containing menu items: Eventlog, Network, FTP, M-Bus Drivers, M-Bus Level Converter, Tariffs, MQTT, BACnet IP, and BACnet IP BBMD. The main content area is titled 'MQTT' and includes the following fields and options:

- MQTT** (checked): Active
- Host**: Text input field
- Port**: Text input field
- User**: Text input field
- Password**: Password input field with a toggle for visibility
- Prefix for all topics**: Text input field
- Send keepalive
- Retain messages
- Allow insecure connections
- Use TLS (SSL)
- Quality of Service**: Dropdown menu set to 'QoS 1, at least once'
- Version**: Dropdown menu set to '3.1'
- Private key for TLS**: File selection field showing 'No file chosen'
- Certificate for TLS**: File selection field showing 'No file chosen'
- CA-Chain**: File selection field showing 'No file chosen'
- Save**: Blue button at the bottom right.

The M-Center can upload data via the MQTT protocol to a broker. On this broker you can subscribe to the data from the M-Center.

- **Host name and Port:** Set the name and communication port of the broker.
- **User and password:** If your MQTT broker need these authentication parameters you can set them here.
- **Prefix:** The broker will show the M-Center under this prefix. This field is optional.
- **Version:** Set the MQTT version. You can choose between versions 3.1, 3.1.1 and 5.

Quality of Service (QoS) is a concept in MQTT that regulates the reliability and guarantees for the delivery of messages between a client (M-Center) and a broker. There are three different QoS levels in MQTT:

1. **QoS 0 (At most once):** This level offers the lowest guarantee of delivery. The message is simply sent without confirmation and there is no guarantee that it will arrive. There is no retry. This level is the fastest and is usually sufficient.

2. QoS 1 (At least once): At this level, the message is delivered at least once. The client (M-Center) sends the message and the recipient confirms receipt. If the client (M-Center) does not receive confirmation, it sends the message again. This ensures that the message arrives at least once, but there is a possibility that it will be received several times.
3. QoS 2 (Exactly once): This is the highest level of delivery guarantee. Here it is ensured that the message arrives exactly once. The client (M-Center) sends the message, the recipient confirms receipt and an acknowledgement of receipt of the confirmation is sent. This ensures that the message is received exactly once.

The choice of QoS level depends on the requirements of the application. In situations where higher reliability is required, a higher QoS level can be selected, but at the cost of increased network load and lower throughput.

MQTT Topics

```

▼ topic1
  ▼ topic2
    ▼ emu
      ▼ mcenter
        ▼ 10:2C:EF: [redacted]
          ▶ config (141 topics, 141 messages)
            ▼ meterreading
              ▼ 22400077
                ▼ byregister
                  0 = 22400077
                  1 = 326375
                  2 = 0
                  3 = 295.925
                  4 = 4.986
                  5 = 0
                  6 = 0
                  7 = 0.205
                  8 = 0.069
                  9 = 0.068
                  10 = 0.068
                lastreadout = 1718104579
              ▼ byobis
                1-0:1.8.1 = 295.925
                1-0:1.8.2 = 4.986
                1-0:2.8.1 = 0
                1-0:2.8.2 = 0
                1-0:3.8.1 = 0.205
                1-0:3.8.2 = 0.069
                1-0:4.8.1 = 0.068
                1-0:4.8.2 = 0.068

▼ topic1
  ▼ topic2
    ▼ emu
      ▼ mcenter
        ▼ 10:2C:EF: [redacted]
          ▼ config
            ▼ meterconfig
              ▼ 22400077
                nameofmeter = 22400077
                lastreadout = 1718104579
                serial = 22400077
                medium = Electricity
                primaryaddress = 121
                manufacturerid = EMU
                baudrate = 2400
                battery = false
              ▼ byregister
                ▼ 0
                  divisor = 0
                  unit = None
                  cfgunit = none
                  phase = 0
                  tariff = 0
                  cfgtariff = 0
                  cfgdescription = Parameter set identification
                ▶ 1 (7 topics, 7 messages)
                ▶ 2 (7 topics, 7 messages)
                ▶ 3 (7 topics, 7 messages)
                ▶ 4 (7 topics, 7 messages)
                ▶ 5 (7 topics, 7 messages)
                ▶ 6 (7 topics, 7 messages)
                ▶ 7 (7 topics, 7 messages)
                ▶ 8 (7 topics, 7 messages)
                ▶ 9 (7 topics, 7 messages)
                ▶ 10 (7 topics, 7 messages)
              ▼ byobis
                ▼ 1-0:1.8.1
                  divisor = 1000
                  unit = Wh
                  cfgunit = kWh
                  phase = 0
                  tariff = 1
                  cfgtariff = 1
                  cfgdescription = Active energy import
                ▶ 1-0:1.8.2 (7 topics, 7 messages)
  
```

The topics are structured as follows:

- /topic1/topic2: Set in the MQTT settings under “Prefix for all topics”.
- /emu/mcenter: Predefined topic structure.
- /10:2C:EF:12:34:56: Corresponds to the serial number / MAC address of the M-Center.
- /meterreading and /config/meterconfig: Can’t be changed and indicates whether the following data is a device or configuration readout.
- /24201234: Corresponds to the serial number of the meter.
- /byregister und /byobis: Can’t be changed and indicates whether the following data was read out via register number or OBIS-code.
- /0: Corresponds to the register number of the meter.
- /1-0:1:8:1: Corresponds to the OBIS code of the register.



Note: If you want your Data to be uploaded into a Topic by OBIS-Code you need to set the correct OBIS-Code on the desired registers. The OBIS-Codes are described in the chapter Modbus Server.

BACnet IP

The settings appear once the “Active” option is chosen.

The screenshot shows the 'Settings' menu on the left with 'Network' selected. The main content area displays the 'BACnet IP' configuration page. The 'Active' checkbox is checked. Below it are options for 'BBMD active' and 'Continuous reading', both unchecked. There are input fields for 'D-Net number' (1000), 'Port' (47808), and 'Device instance number' (1233214). A blue 'Save' button is at the bottom.

To add your M-Center into your BACnet environment you need to set the D-Net-Number, the port and the Device instance number and activate certain options by clicking on the following boxes:

- **BBMD active:** This option allows for readout over all BBMD devices added in **BACnet BBMD**.
- **Continuous reading:** The M-Center reads all connected devices continually to keep the values as up to date as possible. This excludes any devices with the “battery” flag set to avoid draining the battery.



Note: If the option “permanent readout” is activated the M-Center will only save the values read at the readout intervals. The permanently read out values are only updated in your BACnet and further interfaces.



Note: The M-Center uses the two-hop broadcast method.

Save the settings by clicking on the blue “Save” button. Cancel any changes made by leaving the sub menu without saving.

BACNet BBMD

The screenshot shows the 'Settings' sidebar on the left with options: Scan, Add M-Bus Devices, Eventlog, Network, FTP, and M-Bus Drivers. The main content area is titled 'BACNet IP BBMD' and contains the following fields:

- IP address**: An empty text input field.
- UDP port**: A text input field containing the value '47808'.
- Subnet mask**: An empty text input field.
- Add**: A large blue button.
- Device List**: A table with two entries:

IP	port	Action
10.255.255.146	47808	Delete
192.168.1.204	47808	Delete

You can add your BACnet BBMD devices here. Enter the IP-address, the subnet mask and the UDP port of the device into the corresponding fields and save the device by clicking on “Add”.

You can delete added devices by selecting them in the list and clicking “Delete”.

Automatic Upload into Joulio-Web

The settings appear once the “Active” option is chosen.

The screenshot shows the 'Settings' sidebar on the left with options: Scan, Add M-Bus Devices, Eventlog, Network, FTP, and M-Bus Drivers. The main content area is titled 'Joulio-Web' and contains the following fields:

- Active**: A checked checkbox.
- New certificate**: A file selection field showing 'No file chosen'.
- Joulio-Web-Server URL**: A text input field containing '10.255.255.76'.
- Port**: A text input field containing '4321'.
- Client ID**: A text input field containing '6'.
- Save**: A large blue button.

To add the M-Center to your Joulio-Web energy management software you need to set it up here. Enter the Joulio-Web server URL, the desired port and your Client-ID in the corresponding fields. You must then upload the configuration file which the Joulio-Web provided in the “New certificate” field. The file has the .pem format.

Save and Load Configuration

In this sub menu, you can export the configuration file of your M-Center or import an existing configuration file from another M-Center or M-Bus Center. The configuration file is a .json file.

To import a configuration file, click on the “No file chosen” field and select the desired file. Then click on “Apply configuration file” to apply the selected file.

If you click on “Export configuration file”, it will be downloaded immediately via your browser.

Manual Data Export

To export device data manually please click on the **Export** button on the left sidebar (see picture). In this menu you can set the desired time frame, the format of the export (.csv or .json) and the separator (if .csv is chosen) of the export.

Choose from which device(s) you want to export the data by checking the box next to their name and click on “Export” to ready the data on the M-Center. The exported data appears in a list under the “Export” button. If the data does not appear immediately, please reload the page. From this list you are now able to download any data you readied individually by clicking on “Download” on the desired files.

The options “Download all files” and “Delete all files” appear as soon as there are readied files available. These options download or delete all files in the list.

The export file is labeled as follows: DataExport-“Serial number”-“Name of device”-“Device-ID”-“Serial number”-“date and time of export”.csv/.json



Note: If a device has no data stored for the chosen time frame the M-Center will not export a file for this device.

API

You can also download the current data of a connected device via the API of the M-Center. Enter the following link into your Browser:

[http://\[IP-Address of the M-Center\]/app/api/serial/\[Serial number of the device\].\[csv or json\]](http://[IP-Address of the M-Center]/app/api/serial/[Serial number of the device].[csv or json])

This query provides the newest data of the device. Depending on your settings this may be the current readout or the newest data logger entry.

Reboot

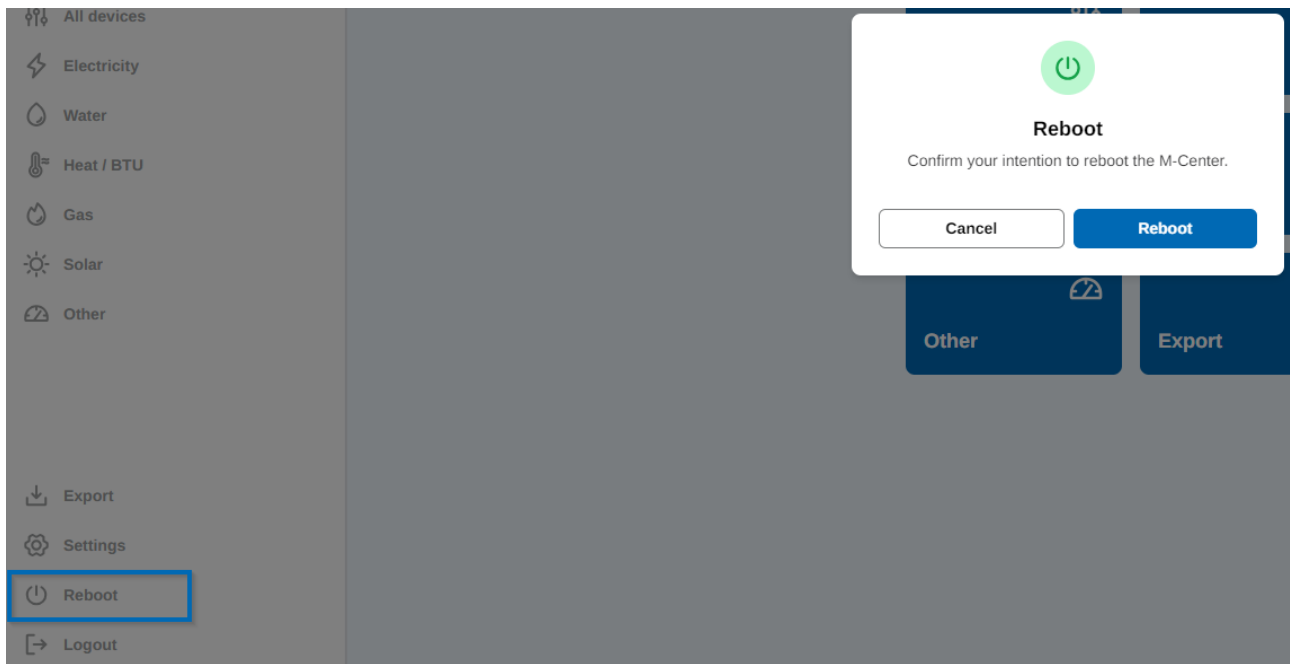

The EMU M-Center can be rebooted directly via the web interface by clicking on the “Export” button in the left sidebar (see picture).

This reboot needs a confirmation. Once confirmed the M-Center reboots and is available again after one minute.



Note: This reboot is a programmed reboot that should be used instead of the “Reset” button if a restart is necessary.

Logout

You can log out of the web interface and return to the login screen via the “Logout” button on the left sidebar.

Device Management

To review the measurement values of connected and added devices please follow these steps:

- Click on **Home** in the left sidebar. In the overview on the main web page, you can choose between all the different device categories.
- For an overview over all connected devices, click on **All devices** in the left sidebar.
- For a categorized overview of all connected devices click on the desired category on the left sidebar. This allows you, for example, to list connected electricity meters only.

On the respective lists you can add a new device with folder button on the top right. On the right of this option, you can sort the list by Name, Primary address, Secondary address, Manufacturer or Last readout.

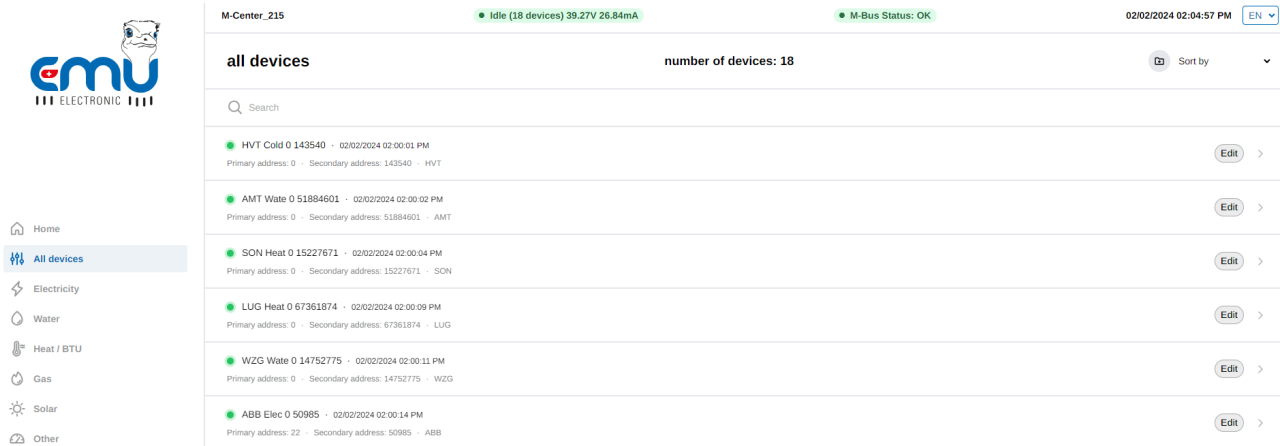

The screenshot shows the M-Center web interface. On the left is a sidebar with navigation icons for Home, All devices (selected), Electricity, Water, Heat / BTU, Gas, Solar, and Other. The main content area displays the 'all devices' list for 'M-Center_215'. At the top, it shows 'Idle (18 devices) 39.27V 26.84mA' and 'M-Bus Status: OK'. Below this is a search bar and a 'Sort by' dropdown. The device list contains the following entries:

Device Name	Last Readout	Primary Address	Secondary Address	Action
HVT Cold 0 143540	02/02/2024 02:00:01 PM	0	143540	Edit
AMT Wate 0 51884601	02/02/2024 02:00:02 PM	0	51884601	Edit
SDN Heat 0 15227671	02/02/2024 02:00:04 PM	0	15227671	Edit
LUG Heat 0 67361874	02/02/2024 02:00:09 PM	0	67361874	Edit
WZG Wate 0 14752775	02/02/2024 02:00:11 PM	0	14752775	Edit
ABB Elec 0 50985	02/02/2024 02:00:14 PM	22	50985	Edit

Once you have found the desired device you can configure it by clicking on the device or the “Edit” button.

The three blue buttons in the configuration window from left to right are:

- Instant readout of this device
- Create a driver from this device's settings
- Delete the device from the list



Warning: Deleting a device also deletes all historical data on the M-Center of this device.

The configuration window has different tabs depending on the device type.

Default

The fields “Name”, “Site”, “Cost unit” and “Comment” are optional and can be used to describe and distinguish the devices. The field “Medium” can be used to change the device category. Readout cycle sets a specific readout interval for this device. This setting only affects this device and does not change the global readout interval. If the option “default” is set, the device adopts the global setting made in “General settings”.

M-Bus

- Primary and Secondary address: Set the primary or secondary address of this device manually.
- Manufacturer: This field cannot be changed and is purely informative.
- Battery: If this device is battery operated you can set a flag here. Devices with this flag are exempt from certain options to ensure a long battery life.
- Baud rate: Set the baud rate for this device.
- M-Bus medium: This field cannot be changed and is purely informative. This medium is set by the M-Bus telegram and can differ from the default medium.
- M-Bus version: This field cannot be changed and is purely informative.
- Address mode: Choose whether the device should be read out via the primary or secondary address.
- snd/NKE: Set this option if you want the M-Center to communicate via the send/acknowledge protocol with the connected M-Bus devices.
- App reset subcode: Add your desired reset commands sent to the connected M-Bus devices.

Modbus

- Device address: Previously also known as slave ID.
- Byte order: Set whether your device sends its data in big-endian or little-endian byte order.
- Word order: Also referred to as bit significance
- For devices with Modbus TCP interface you need to set the Host name/IP address and the Port.
- For devices with Modbus RTU interface you need to set the baud rate, number of bytes, the parity and the stop bit.

BACnet IP

Enter the device instance number of this device.

Configuration of Device Registers

You can open an overview of all registers by clicking on the arrow button on the right of the “Edit” button.

The screenshot displays the M-Center interface for device EMU Elec 0 22010814. A table lists several registers with their current values and 'Edit' buttons. The second register, '0.00 kWh Active energy import', is selected. An 'Edit Device Data' dialog box is open on the right, showing configuration options for the selected register, including Name, Tariff, Phase, Unit, Divisor, and OBIS code.

Register Name	Value	Register ID
686.14 kWh Active energy import	686.14	0 - 1-0.1.8.1
0.00 kWh Active energy import	0.00	1 - 1-0.1.8.2
0.00 kWh Active energy export	0.00	2 - 1-0.2.8.1
0.00 kWh Active energy export	0.00	3 - 1-0.2.8.2
23.73 kvarh Reactive energy import	23.73	4 - 1-0.3.8.1
0.00 kvarh Reactive energy import	0.00	5 - 1-0.3.8.2



*Note: Changing one of the following fields only affects the display of the registers on the M-Center web interface and your exports. If you change the name of an “active energy” register to “reactive energy” the M-Center will still read out the active energy register but label it “reactive energy”. Please make sure to adjust these fields according to the readout protocol.

- Name: Choose the name in the drop-down menu. This name is purely informative and will also be displayed in your exports.
- If the chosen register is of a specific tariff, you can set the tariff here.
- If the chosen register is of a specific phase, you can set the phase here.
- Unit: Choose the unit of this register.
- Divisor: Enter a dividing factor for the register. This factor is automatically applied to the read-out data and is particularly suitable for displaying large values in a more manageable kilo, mega or giga format.
- OBIS code: Here you can enter the correct OBIS code for the register.



Note: The option “–not yet configured–” in the fields “Name” and “Unit” can be selected to deactivate the upload of this register to Joulio-Web.

Save to database

This option allows you to select whether this register should be saved in your database. This allows you to “switch off” any superfluous registers and save storage space.

If you upload your data to a Joulio-Web platform, registers that do not have this option activated will not be uploaded.



Note: Regardless of the configuration, the read values are available via HTTP-API, BACNet, OPC-UA, MQTT, Modbus Server.

Modbus Server

If the Modbus license on the EMU M-Center is activated, the M-Center functions as a Modbus TCP server and provides the values read from the connected devices via Modbus TCP.

The generic connection parameters are:

- TCP port: 502
- Modbus device number (slave address): corresponds to the “Modbus TCP server device number”
- Byte-order: high (big endian)
- Word-order: MSB -> LSB
- Start value for the registers: 1

The assignment of a register to a Modbus address is carried out according to the following table and increases by 30 for each register:

Register to read	Register float32	Register uint64
0	12000	12002
1	12030	12032
2	12060	12062
....
100	15000	15002

The following procedure is recommended for a simplified query of identical measurement values:

- Store the OBIS-code for the corresponding measurement values.
- The Modbus registers can be queried accordingly using the mapping table below:

OBIS-Code	Description	Medium	Register float32	Register uint64
1-0:1.8.0	Active energy import, meter reading, total	Electricity	1000	1002
1-0:1.8.1	Active energy import, meter reading, tariff 1	Electricity	1030	1032
1-0:1.8.2	Active energy import, meter reading, tariff 2	Electricity	1060	1062
1-0:1.8.3	Active energy import, meter reading, tariff 3	Electricity	1090	1092
1-0:1.8.4	Active energy import, meter reading, tariff 4	Electricity	1120	1122
1-0:2.8.0	Active energy export, meter reading, total	Electricity	1150	1152
1-0:2.8.1	Active energy export, meter reading, tariff 1	Electricity	1180	1182
1-0:2.8.2	Active energy export, meter reading, tariff 2	Electricity	1210	1212
1-0:2.8.3	Active energy export, meter reading, tariff 3	Electricity	1240	1242
1-0:2.8.4	Active energy export, meter reading, tariff 4	Electricity	1270	1272
1-0:3.8.0	Reactive energy import, meter reading, total	Electricity	1300	1302
1-0:3.8.1	Reactive energy import, meter reading, tariff 1	Electricity	1330	1332
1-0:3.8.2	Reactive energy import, meter reading, tariff 2	Electricity	1360	1362
1-0:3.8.3	Reactive energy import, meter reading, tariff 3	Electricity	1390	1392
1-0:3.8.4	Reactive energy import, meter reading, tariff 4	Electricity	1420	1422

OBIS-Code	Description	Medium	Register float32	Register uint64
1-0:4.8.0	Reactive energy export, meter reading, total	Electricity	1450	1452
1-0:4.8.1	Reactive energy export, meter reading, tariff 1	Electricity	1480	1482
1-0:4.8.2	Reactive energy export, meter reading, tariff 2	Electricity	1510	1512
1-0:4.8.3	Reactive energy export, meter reading, tariff 3	Electricity	1540	1542
1-0:4.8.4	Reactive energy export, meter reading, tariff 4	Electricity	1570	1572
1-0:9.8.0	Apparent energy export, meter reading, total	Electricity	1600	1602
1-0:9.8.1	Apparent energy export, meter reading, tariff 1	Electricity	1630	1632
1-0:9.8.2	Apparent energy export, meter reading, tariff 2	Electricity	1660	1662
1-0:9.8.3	Apparent energy export, meter reading, tariff 3	Electricity	1690	1692
1-0:9.8.4	Apparent energy export, meter reading, tariff 4	Electricity	1720	1722
1-0:1.7.0	Apparent power import, current value, total	Electricity	1750	1752
1-0:21.7.0	Apparent power import, current value, phase 1	Electricity	1780	1782
1-0:41.7.0	Apparent power import, current value, phase 2	Electricity	1810	1812
1-0:61.7.0	Apparent power import, current value, phase 3	Electricity	1840	1842
1-0:2.7.0	Apparent power export, current value, total	Electricity	1870	1872
1-0:22.7.0	Apparent power export, current value, phase 1	Electricity	1900	1902
1-0:42.7.0	Apparent power export, current value, phase 2	Electricity	1930	1932
1-0:62.7.0	Apparent power export, current value, phase 3	Electricity	1960	1962
1-0:3.7.0	Reactive power import, current value, total	Electricity	1990	1992
1-0:23.7.0	Reactive power import, current value, phase 1	Electricity	2020	2022
1-0:43.7.0	Reactive power import, current value, phase 2	Electricity	2050	2052
1-0:63.7.0	Reactive power import, current value, phase 3	Electricity	2080	2082
1-0:4.7.0	Reactive power export, current value, total	Electricity	2110	2112
1-0:24.7.0	Reactive power export, current value, phase 1	Electricity	2140	2142
1-0:44.7.0	Reactive power export, current value, phase 2	Electricity	2170	2172
1-0:64.7.0	Reactive power export, current value, phase 3	Electricity	2200	2202
1-0:9.7.0	Apparent power, current value, total	Electricity	2230	2232
1-0:29.7.0	Apparent power, current value, phase 1	Electricity	2260	2262

OBIS-Code	Description	Medium	Register float32	Register uint64
1-0:49.7.0	Apparent power, current value, phase 2	Electricity	2290	2292
1-0:69.7.0	Apparent power, current value, phase 3	Electricity	2320	2322
1-0:11.7.0	Current, current value, Total	Electricity	2350	2352
1-0:31.7.0	Current, current value, phase 1	Electricity	2380	2382
1-0:51.7.0	Current, current value, phase 2	Electricity	2410	2412
1-0:71.7.0	Current, current value, phase 3	Electricity	2440	2442
1-0:32.7.0	Voltage, current value, phase 1	Electricity	2470	2472
1-0:52.7.0	Voltage, current value, phase 2	Electricity	2500	2502
1-0:72.7.0	Voltage, current value, phase 3	Electricity	2530	2532
1-0:33.7.0	Power factor, current value, phase 1	Electricity	2560	2562
1-0:53.7.0	Power factor, current value, phase 2	Electricity	2590	2592
1-0:73.7.0	Power factor, current value, phase 3	Electricity	2620	2622
1-0:14.7.0	Frequency, current value	Electricity	2650	2652
8-0:1.0.0	Water volume, meter reading	Water (Coldwater)	3000	3002
9-0:1.0.0	Water volume, meter reading	Water (Warmwater)	3030	3032
7-0:3.0.0	Volume, meter reading	Gas	3060	3062
7-0:3.0.1	Volume, meter reading tariff 1	Gas	3090	3092
7-0:3.0.2	Volume, meter reading tariff 2	Gas	3120	3122
7-0:3.0.3	Volume, meter reading tariff 3	Gas	3150	3152
7-0:3.0.4	Volume, meter reading tariff 4	Gas	3180	3182
7-0:3.0.5	Volume, meter reading tariff 5	Gas	3210	3212
7-0:3.0.6	Volume, meter reading tariff 6	Gas	3240	3242
6-0:1.0.0	Energy, meter reading	Combined Heat/Cold Meter for Heating	3500	3502
6-0:2.0.0	Volume, meter reading	Combined Heat/Cold Meter for Heating	3530	3532
6-0:3.1.0	Flow temperature	Combined Heat/Cold Meter for Heating	3560	3562
6-0:3.2.0	Return temperature	Combined Heat/Cold Meter for Heating	3590	3592
6-0:3.3.0	Flow rate	Combined Heat/Cold Meter for Heating	3620	3622
6-0:8.0.0	Power	Combined Heat/Cold Meter for Heating	3650	3652
5-0:1.0.0	Energy, meter reading	Combined Heat/Cold Meter for Cooling	3680	3682
5-0:2.0.0	Volume, meter reading	Combined Heat/Cold Meter for Cooling	3710	3712
5-0:3.1.0	Flow temperature	Combined Heat/Cold Meter for Cooling	3740	3742
5-0:3.2.0	Return temperature	Combined Heat/Cold Meter for Cooling	3770	3772
5-0:3.3.0	Flow rate	Combined Heat/Cold Meter for Cooling	3800	3802
5-0:8.0.0	Power	Combined Heat/Cold Meter for Cooling	3830	3832
5-0:1.0.0	Energy, meter reading	Cold Meter	4000	4002
5-0:2.0.0	Volume, meter reading	Cold Meter	4030	4032
4-0:1.0.0	meter reading without unit	Heat Meter	4060	4062
4-0:2.0.0	Volume, meter reading	Heat Meter	4090	4092
4-0:3.1.0	Flow temperature	Heat Meter	4120	4122
4-0:3.2.0	Return temperature	Heat Meter	4150	4152

OBIS-Code	Description	Medium	Register float32	Register uint64
4-0:3.3.0	Flow rate	Heat Meter	4180	4182

Example

You want a readout of the active energy of an EMU Professional II. The Modbus device number is 9, the register to be read is 3 and the stored OBIS code is 1-0:1.8.1

- **EMU Elec 129 23022814**

Last reading: 04/11/2024 01:00:25 PM · Manufacturer: EMU · Medium: Electricity · Modbus TCP Server device number 9

180.47 kWh Active energy import

Tariff 1

Logging: On · register: 3 · 1-0:1.8.1

The readout in this example uses modpoll

Readout as Float32 via OBIS code 1-0:1.8.1 with Modbus register address 1030

```
modpoll.exe -l -m tcp -t 4:float -i -f -r 1030 -a 9 -c 1 -p 502 [M-Center Host or IP]
```

Readout as Float32 via register number 3 with Modbus register address 12090

```
modpoll.exe -l -m tcp -t 4:float -i -f -r 12090 -a 9 -c 1 -p 502 [M-Center Host or IP]
```

Both variants transmit the current meter reading as a floating-point number.

```
-- Polling slave...
[1030]: 180.47005
```

Troubleshooting

One or more Devices cannot be read

Battery operated devices oftentimes have an internal access counter. This counter prevents the readout of device data after a certain number of readouts in a predefined time frame (usually one day). This functionality exists to prolong the battery life of these devices. For further questions regarding the battery life of such devices, please contact the manufacturer.

No Device can be read

Check for short circuits on the M-Bus:

- The M-BUS voltage should be around 40VDC.
- The current on the M-BUS should be in a reasonable scope. EMU energy meters use 1.5mA on average per device, while battery powered devices use up to 3 or 4 times that amount.

Make sure to avoid any ring topologies on the bus.

If the M-Bus current indicator on the web interface shows 0mA, no devices have been connected via M-Bus to the M-Center.

Multiple Devices cannot be read

- Check if all these devices are connected via the same strand and if that strand is interrupted.
- Check the M-Bus voltage on the device (with a Multimeter). The voltage measured should be between 36VDC and 41VDC.
- Check for a faulty addressing mode on primary or secondary addressing modes. Multiple devices with the same address leads to communication errors.

One Device cannot be read

- Check if the selected readout interval is supported by the device.
- Check if the device is connected correctly.
- Check the M-BUS voltage on the device (with a Multimeter). The voltage measured should be between 36VDC and 41VDC.
- Check if the device communicates if it alone is connected to a different M-Bus master. If this works follow the points under Multiple devices cannot be read and No device can be read.

Measurement on the M-Center differs from the Measurement on the Device by a Constant Factor

Check the divisor of the affected register. If needed, set the divisor to the correct value.

FTP-Upload Fails

Try and test the connection via another program. Possible cause for this error:

- One of the parameters is incorrect.
- No DNS-server address is given.
- The M-Center has no Internet connection
- The M-Center has no access rights to the specified directory.
- The user may be barred from the FTP server due to repeated failed attempts.
- The set user has no access rights on the file path.

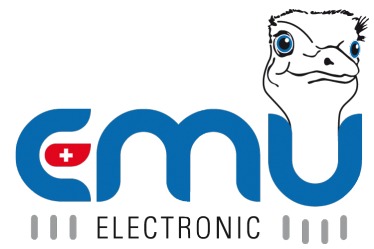

EMU Metering GmbH

Friemarier Str. 38
99867 Gotha
Deutschland

Phone: +49 (0)3621 510 40 70

hello@emu-metering.de
www.emu-metering.de

EMU Electronic AG

Jöchlerweg 2
CH-6340 Baar
Switzerland

Phone: +41 (0)41 545 03 00

helpdesk@emuag.ch
www.emuag.ch