



# M-CENTER

M-BUS, MODBUS & MORE

M-Bus

Modbus RTU RS485

Modbus TCP

MQTT

BACnet IP

OPC UA

LTE SIM Card Modem



EMU - energy meters, data loggers and energy management software straight from the manufacturer - everything from one source.

## GENERAL INFORMATION

The M-Center with built-in heavy duty level converter ensures quick configuration and set-up. Automated readout of up to 250 M-Bus meters and 64 RS485 devices guarantees error-free and continuous data collection for later analysis and billing as per ISO 50001. Energy usage becomes transparent and potential savings identified.

## CUSTOMER BENEFITS

- Built-in M-Bus level converter for 20 / 60 / 120 / 250 M-Bus devices
- Suitable for heat, water, gas and electric meters with M-Bus, Modbus RTU and Modbus TCP
- Web-enabled, remote readout via web browser
- Professional data processing
- Energy usage becomes transparent for targeted measures
- Device Management & Digital Twin

## FEATURES AND REQUIREMENTS AS PER ISO 50001

- Continuous data evaluation
- Visualisation incl. individual graphs
- Automated reporting
- Alerting
- Integration into existing systems
- Support & update service

## EMU M-CENTER: FLEXIBLE, EXPANDABLE

A hardware product with modular firmware - ready for the future. The M-Center is configured entirely using an appealing, user-friendly interface operable with any customary web browser (HTML5). The device management with Joulio-Web allows for simple management of scattered installations.

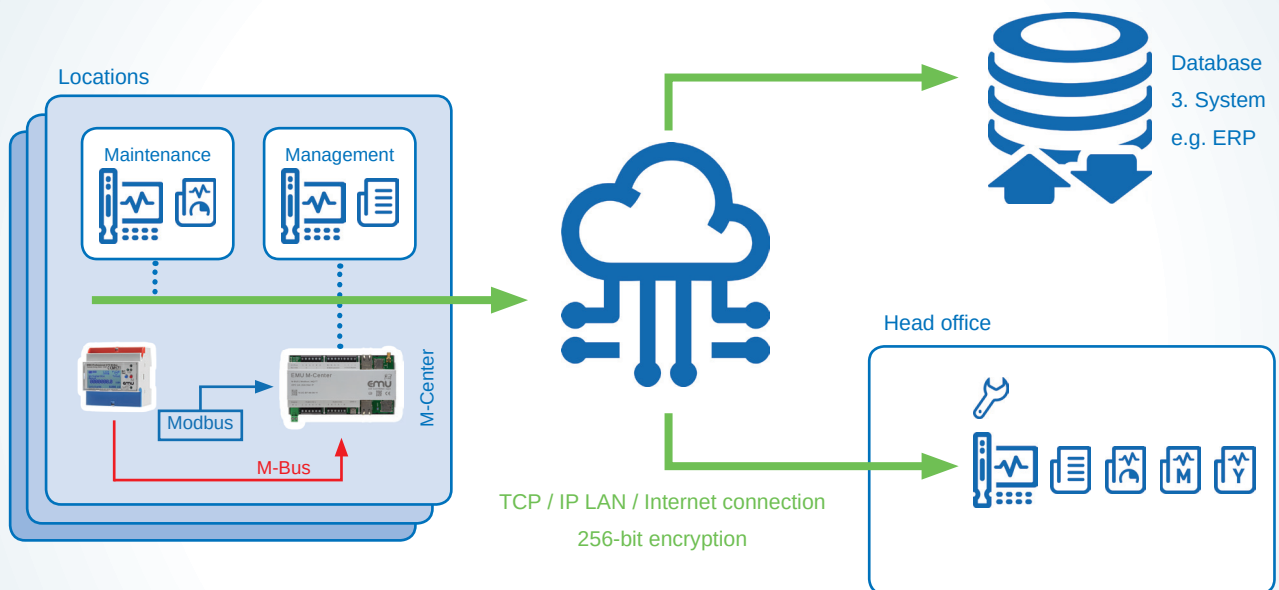

## CUSTOMER BENEFITS

- One hardware
- Firmware upgrade for new features
- Device Management by Joulio-Web
- MQTT, OPC UA, BACnet IP and Modbus RTU and Modbus TCP
- Suitable for energy data management as per ISO 50001



# KEY FEATURES

## GENERAL MENU NAVIGATION

- Home page with user-friendly grouping
- Overview of all meters
- Meter and data logger configuration
- Backup and data export
- Status of the readout is immediately visible

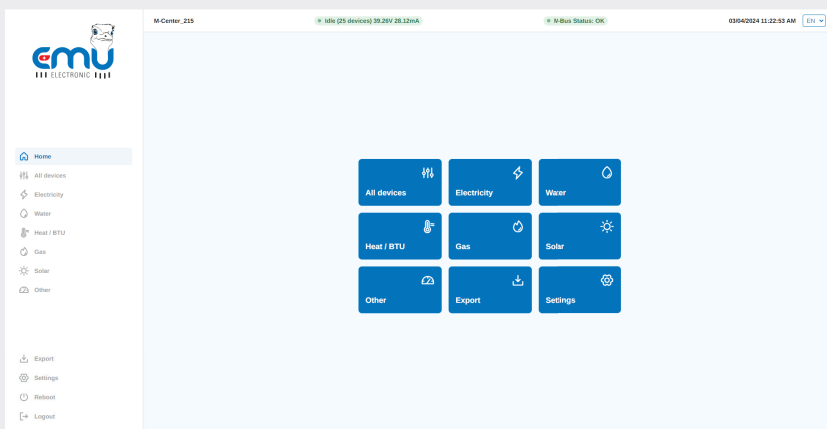

## BMS INTEGRATION

- BACnet IP Gateway with BBMD function
- OPC UA
- MQTT
- Modbus TCP
- Modbus RTU

## SET-UP

- Automatic meter scan
- Supports M-Bus primary and secondary address
- 300, 2400 and 9600 baud  
2400 baud recommended

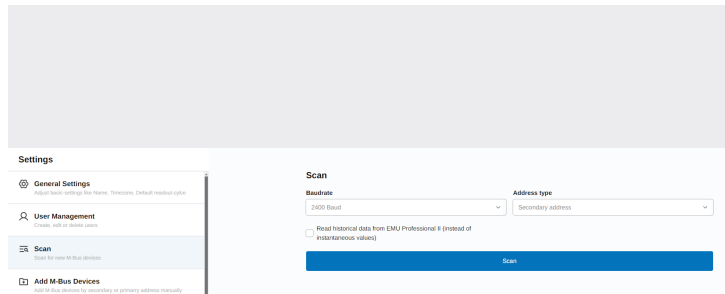

## COMPATIBILITY

- Meters with M-Bus interface per EN 13757-2,-3, e.g. electric, water, heat, gas
- RS485 Modbus RTU
- Modbus TCP
- Device driver by device management

# KEY FEATURES

## HARDWARE AND SOFTWARE

- Integrated high performance level converter
- Internal data storage
- Modular software architecture
- M-Bus short-circuit and excess current monitor

## ALARMS

- Meter readout failure
- M-Bus error flags analysis
- Monitor for communication with third-party systems

# HARDWARE

## INTERFACES

Inputs	2 x M-Bus 2 x RS485 8 x Flex I/O 1x M-Bus sniffer
Interfaces	1 x USB C 1 x Ethernet 10/100 Base RJ45 1 x Ethernet Service Port 1 x LTE Modem (SIM Card)
BMS integration	MQTT BACnet IP OPC UA Modbus RTU and TCP
Power supply	230V

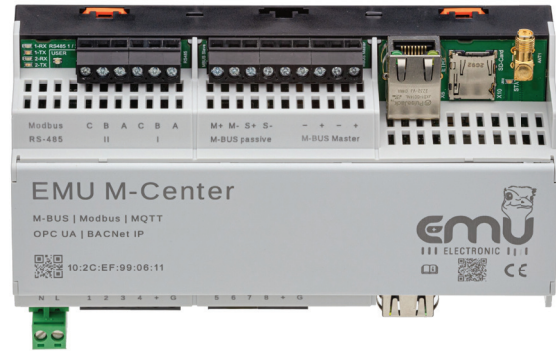

Part number	Designation
210.000.00	EMU M-Center for 20 M-Bus Devices
210.020.01	M-Center   M-Bus License 20 to 60 Devices
210.020.02	M-Center   M-Bus License 20 to 120 Devices
210.020.03	M-Center   M-Bus License 20 to 250 Devices
210.200.00	M-Center   License RS485 32 Devices
210.200.01	M-Center   License RS485 64 Devices
210.200.03	M-Center   License Modbus TCP 20 Devices (Reading)
210.300.00	M-Center   License BACnet IP
210.300.01	M-Center   License OPC UA
210.300.03	M-Center   License MQTT
210.300.04	M-Center   License Modbus TCP (M-Bus to Modbus TCP)





### Access any time, anywhere

The web interface of the EMU M-Center is easily operated from any PC or tablet via web browser.

# 1

## INSTALLATION

Full configuration via IP address and web browser. The EMU M-Center scans all connected meters via M-Bus secondary or primary address. Connects to the higher-level energy management system per ISO 50001 with just a few clicks.

# 2

## PLUG & PLAY CONFIGURATION

The connected meters are marked. Name, location, cost centre and comments are defined by meter.

# 3

## MEASUREMENTS - MEDIUMS

The open, integral energy management system reads all energy meters via M-Bus interface per EN 13757-2, -3. When required, individual device drivers are created on the EMU M-Center, exported and transferred to other M-Center.

In addition to active and reactive energy, the energy meters (electricity) for EMU also provide a number of other measurements, e.g. current, voltage, power ratings, Cos-Phi, frequency, etc. Of course these measurements are archived and transmitted to the higher-level energy management system.

# 4

## SECURITY

The clock is synchronised via Net Time Protocol (NTP) server. Faults are recorded in the event log and reported via e-mail.

## IOT AND INDUSTRY 4.0

The Internet of Things (IoT) has been inspiring the economy and science alike for about 25 years. Machines and systems which communicate with each other automatically, control and optimise themselves are the next level of automation - the so-called Industry 4.0.

The M-Center features modern communication options with a service-based architecture and encrypted communication channels.

## FLEXIBLE SYSTEM EXPANSION

Easy expansion of existing M-Bus systems

- Multi-manufacturer meter readout
- Cost-effective entry into effective, future-oriented energy management as per ISO 50001 along with industrial and residential utility billing.

## M-BUS SYSTEM

- Polarity: Protected against reverse polarity, polarity independent
- Compatible topologies: Star, tree and linear structure
- Two-core, if possible shielded
- J-Y(ST) Y 2 x 2 x 0.8 mm
- Minimum distance to electric circuit, EMC interference
- M-Bus line as short as possible
- Master = EMU M-Center / level converter
- Slave = device, e.g. EMU energy meter

## MULTILINGUAL

The EMU M-Center is successfully being used on an international level. The web interface is multi-lingual.





## M-BUS TO BACNET IP GATEWAY

### B-ASC certified and BBMD function

The M-Center is furthermore an ideal system component for integration into a BACnet IP network. Once an M-Bus device is registered or imported to a Center, it is immediately readable via the BACnet IP. The M-Center and the registered M-Bus devices are each detected as separate device objects with a static list of analogue input objects (M-Bus measurements). Integration into a higher-level BACnet IP system requires virtually no configuration.

## PLUG & PLAY CONFIGURATION

The automatic scan automatically detects and lists all connected M-Bus meters. The meters are then be configured. Each meter is assigned a name, cost centre and comments.

## M-BUS LEVEL CONVERTER OVER USB AND TCP/IP

The M-Center can be used as a M-Bus level converter over USB or TCP/IP. Existing M-Bus software tools can communicate with the M-Bus via USB port or TCP/IP.

## OPC UA

All M-Bus values can be read via OPC UA by the local building management system.

## METERS & READOUT

All energy meters (e.g. water, BTU, electricity and gas) with M-Bus interface per EN 13757-2,-3 (formerly EN1434-2,-3) are read out via two-wire line. Measurements and usage are archived to a SQL database. Two PT1000 temperature sensor are used to record e.g. the indoor and outdoor temperature.

Usage data can be analysed from any computer or tablet via IP address and web browser. The built-in data evaluation (web server) eliminates the need for M-Bus readout software.

## REFERENCE PROJECT: ETH HWW LIVINGSCIENCE

- Over 1300 meters (electricity, water and heat)
- Readout via EMU M-Center
- Web-based access for over 400 users, multilingual
- Individual software expansion

Management always has an overview of energy usage and variances. Just shortly after being set up the EMS software detected a variance (increased water usage) and prevented undesirable additional costs.

Locations

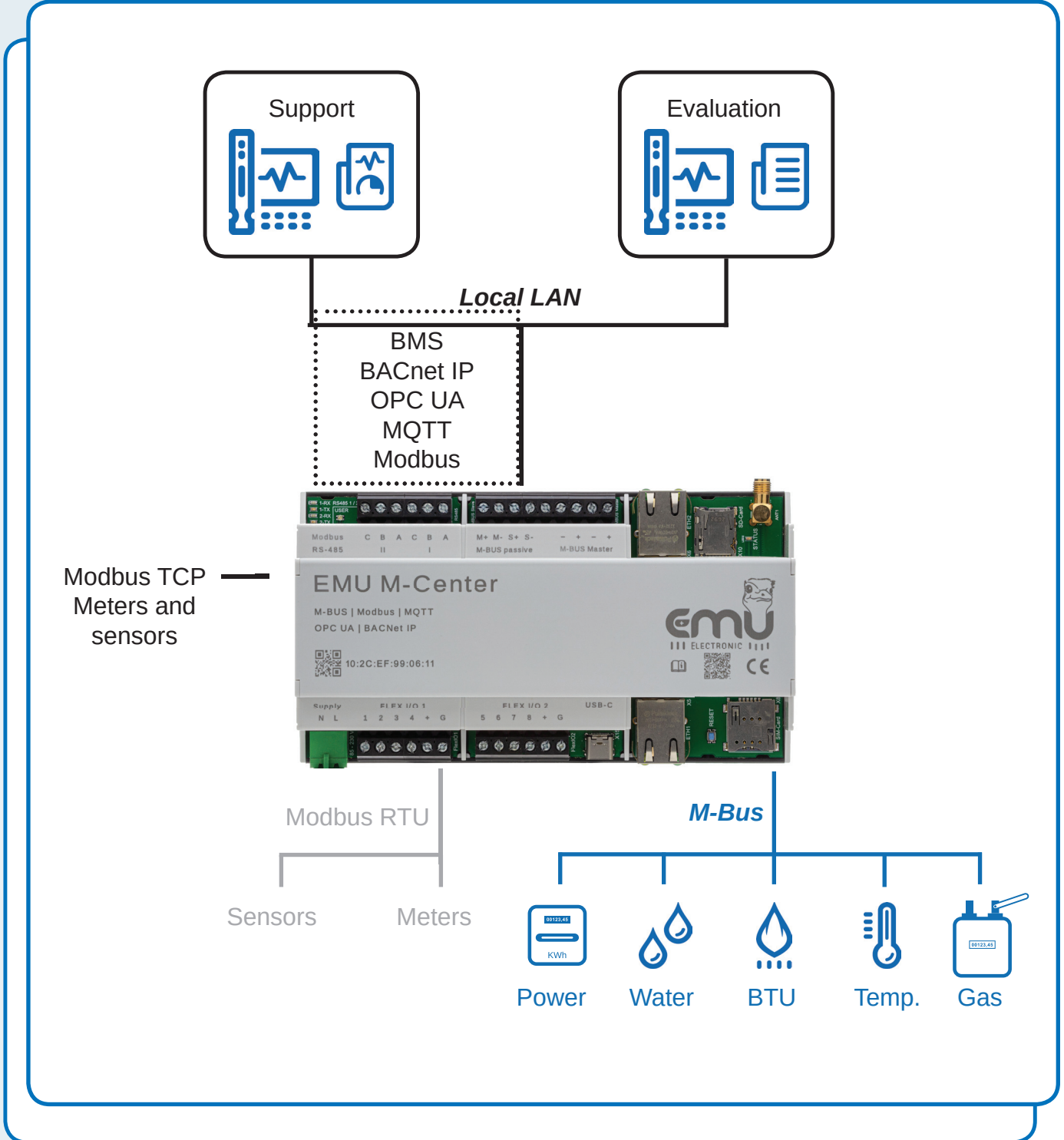

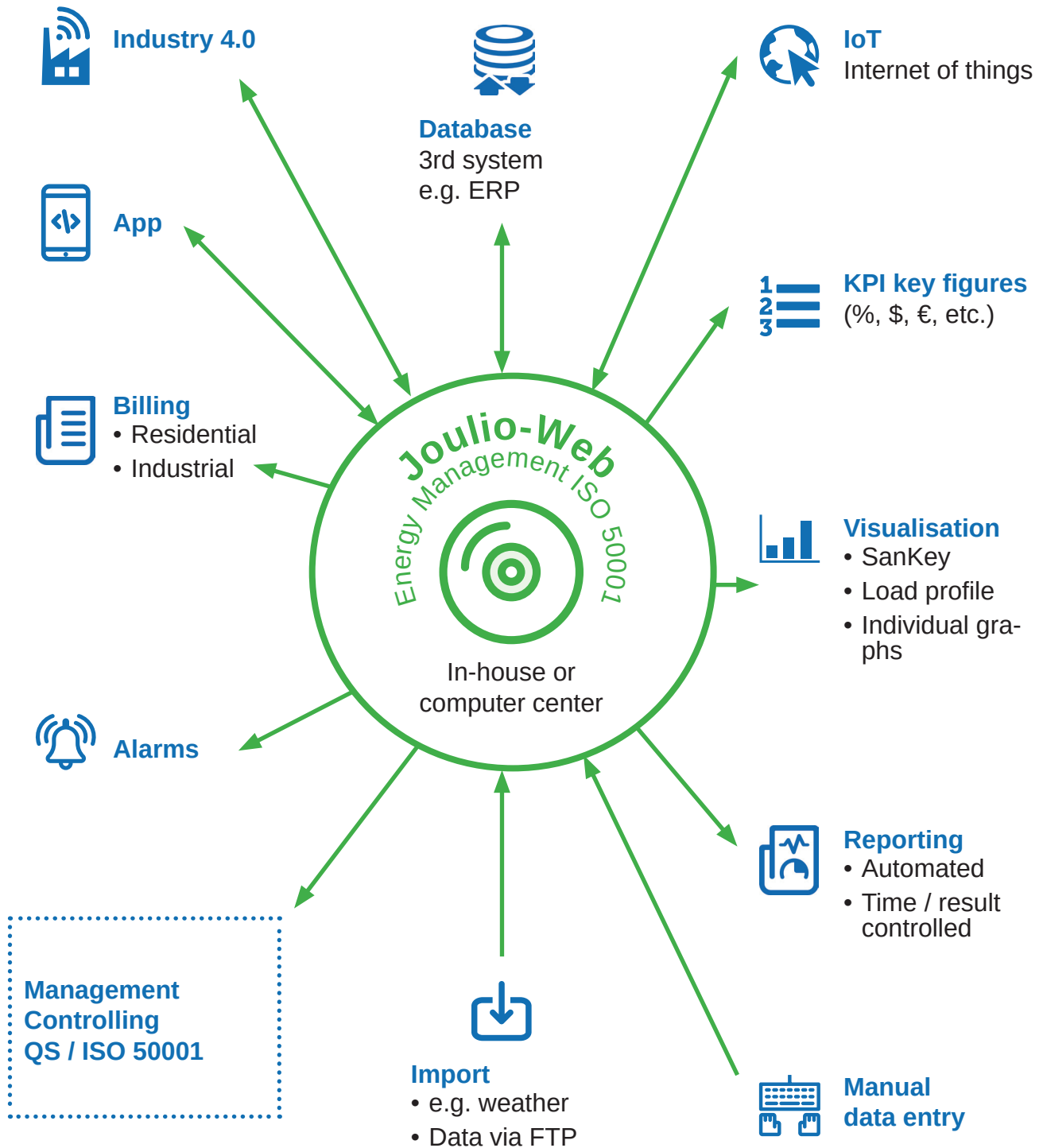

# ORDERING INFORMATION

## EVERYTHING YOU NEED FOR ENERGY MANAGEMENT

	Article number	Designation
<b>EMU M-Center Data logger &amp; Gateway</b>	210.000.00	EMU M-Center for 20 M-Bus Devices
	210.020.01	M-Center   M-Bus License 20 to 60 Devices
	210.020.02	M-Center   M-Bus License 20 to 120 Devices
	210.020.03	M-Center   M-Bus License 20 to 250 Devices
	210.200.00	M-Center   License RS485 32 Devices
	210.200.01	M-Center   License RS485 64 Devices
	210.200.03	M-Center   License Modbus TCP 20 Devices
	210.300.00	M-Center   License BACnet IP
	210.300.01	M-Center   License OPC UA
	210.300.03	M-Center   License MQTT
	210.300.04	M-Center   License Modbus TCP (M-Bus to Modbus TCP)
<b>Energy Management ISO 50001</b>	250.000.00	Joulio-Web SaaS
	250.001.00	Joulio-Web Saas   Charts-App
	250.000.01	Joulio-Web Saas   Meter
<b>Power meters with interface and MID approval</b>	P20A000M	EMU Professional II 3/100 M-Bus, 3x230/400V, 100A
	P21A000M	EMU Professional II 3/5 M-Bus, 3x230/400V,CT /5 + /1A
	950506	EMU 1/40 M-Bus, 230V, 40A
	P20A000T	EMU Professional II 3/100 TCP/IP, 3x230/400V, 100A
	P21A000M	EMU Professional II 3/5 TCP/IP, 3x230/400V,CT /5 + /1A
	P20A000MO	EMU Professional II 3/100 Modbus RTU, 3x230/400V, 100A
	P21A000MO	EMU Professional II 3/5 Modbus RTU, 3x230/400V,CT /5 + /1A

You can upgrade your M-Center licences at any time if the initially licenced number of devices no longer suffices.

## PRODUCT INFORMATION

Number of M-Bus devices	Max. 20 / 60 / 120 / 250, (250 x 1.5mA) see order information
Ports	1 x USB Typ C 1x LTE Modem (SIM card) 1 x Ethernet 10/100 Base RJ45 (LAN) 1 x Ethernet 10/100 Base RJ45 (Service)
Inputs	2 x M-Bus 2 x RS485 8 x Flex I/O
M-Bus level converter	Integrated heavy duty level converter
Data export	.csv and JSON file, other formats upon request
Data storage	8GB internal
Firmware update	Yes, via device management
Backup	Yes, via device management
Configuration	Local and remote configuration via web server

## TECHNICAL DATA

Operating voltage	230V, maximum 1 Ampere
Width	161mm
Temperature range	0-55°C
M-Bus baud rate	300, 2400, 9600
M-Bus standby current	Max. 375mA (250 x 1.5mA), see ordering information
Compatibility	Heat, water, gas and electricity meters with M-Bus per EN 13757-2, -3 (formerly EN1434-3)
Galvanic isolation, short circuit and overload protection	Yes
Security	CE mark
EMC measurement	EN 61000-6-2
Immunity	EN 61000-6-3
M-Bus standard	EN 13757-2,-3
Energy management	Suitable for ISO 50001
BACnet IP	B-ASC certified
Weight	Approx. 400g
Installation	35mm DIN rail
Housing	Polycarbonate, recyclable, non-flammable

## WIRING DIAGRAM

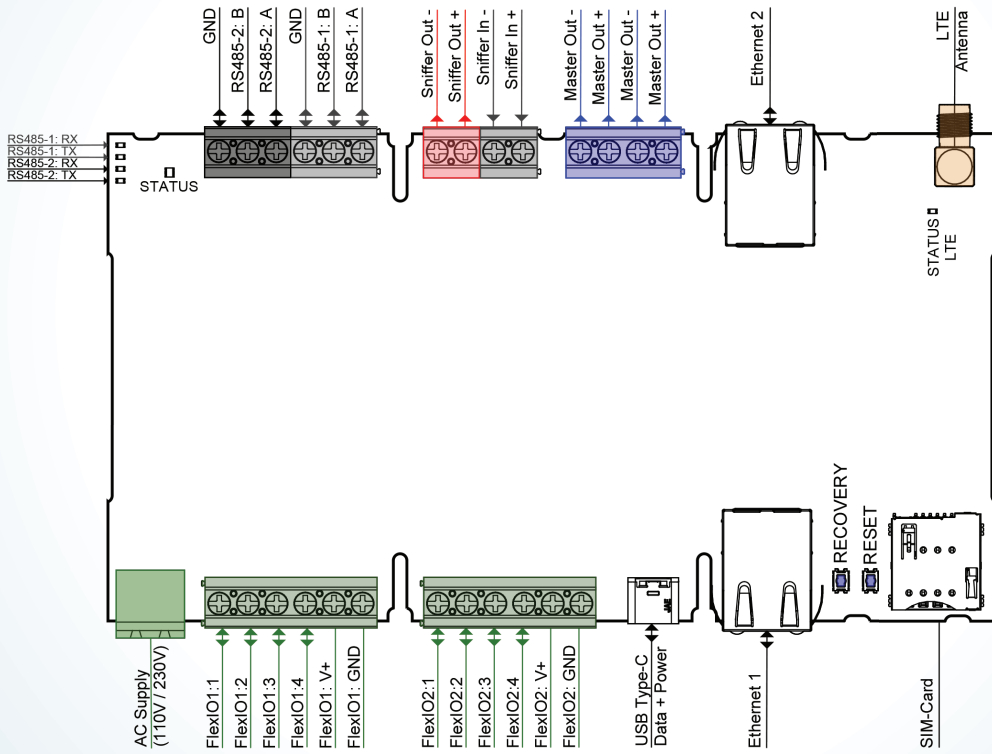

## DIMENSIONAL DRAWING

The M-Center mounts on a DIN rail.

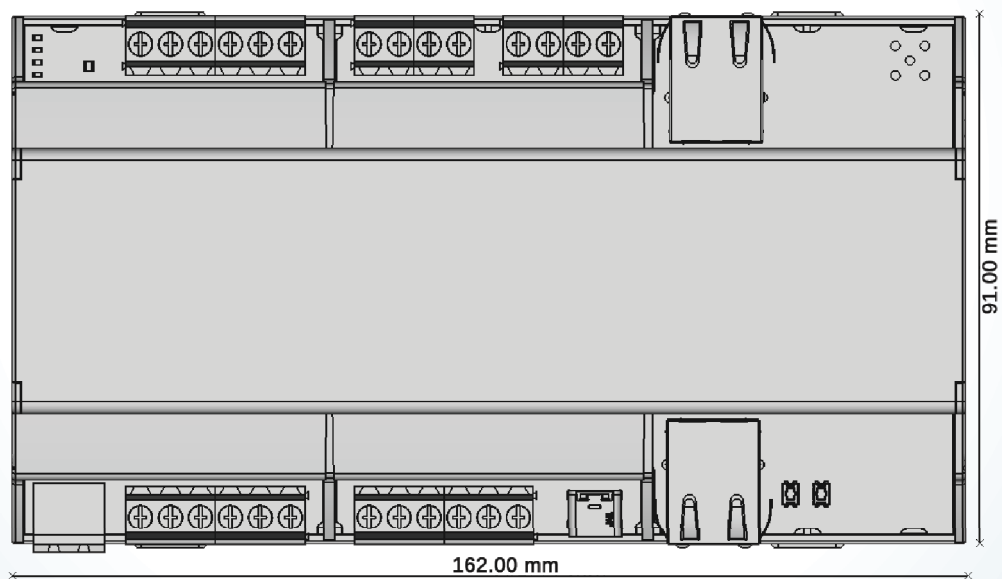

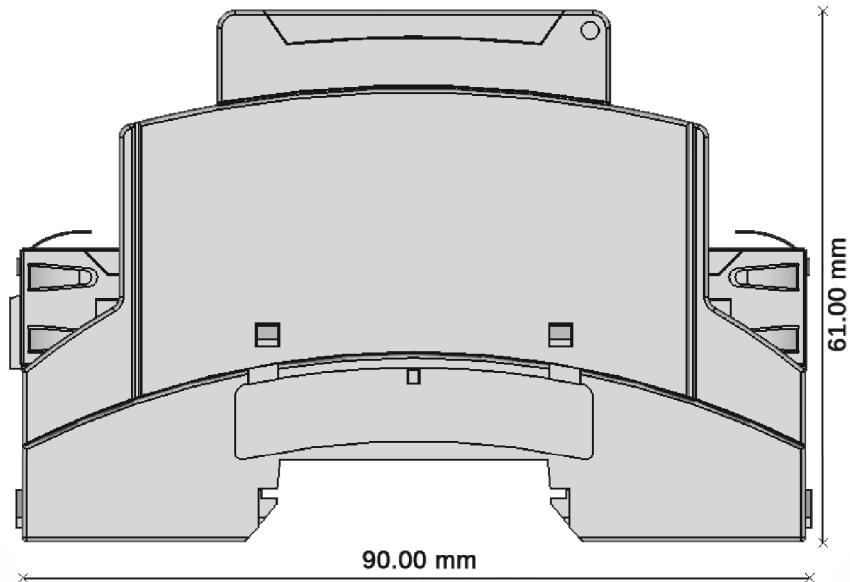

Data specified in the product catalogue has been compiled in all conscience. Changes and errors expressly reserved. "Images similar" does not constitute a term of contract. This is a notice without autonomous scope which merely states the information in the catalogue is preliminary and non-binding in that it may be corrected before or on conclusion of contract. These notices do not provide any contractual scope, particularly any limitation in the rights of the contracting party with respect to liability or warranty.

We compile and update our compatibility lists with utmost care. Please contact our support service to verify compatibility with existing meters.

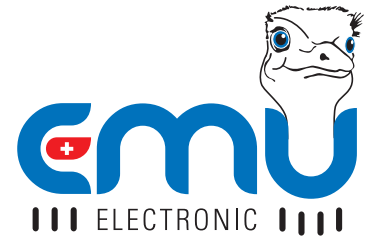

**EMU Electronic AG**

Jöchlerweg 2

6340 Baar

Switzerland

Tel. +41 (0)41 545 03 00

E-Mail: [info@emuag.ch](mailto:info@emuag.ch)

Website: [www.emuag.ch](http://www.emuag.ch)

**Date: 01.10.2024**

Technical changes reserved.